

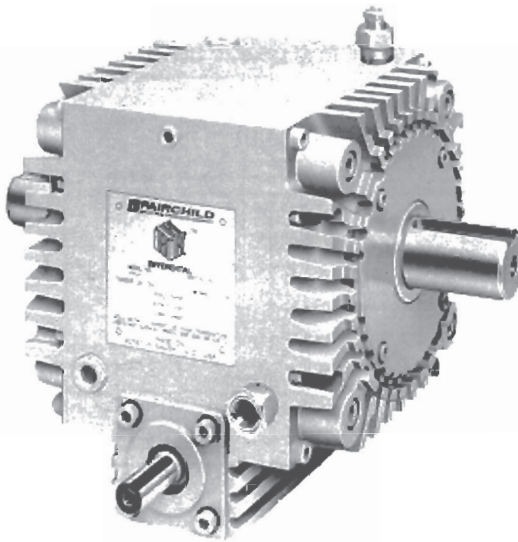

# CUBIC® DIFFERENTIAL TRANSMISSION



## APPLICATIONS

The Specon CUBIC® Differential Transmissions offer a reliable and precise means for adjusting the speed of, or altering the phase of shaft driven equipment. Since torque requirements are very low relative to the torque requirements of the driven machine, the CUBIC® Differentials can adjust the speed up or down or change the rotational position of the driven machine relative to the prime mover. The ease of adjustment, precision of correction and rapidity of response makes the CUBIC® Differentials uniquely qualified for use in machine synchronization, timing adjustment of precise process steps in many applications of automated machinery. Applications include:

- Conveyor drives
- Printing presses
- Converting and textile machinery
- Paper and web cutoff machinery
- Plastic web or film machinery
- Packaging machinery

## FEATURES

- Low correction shaft torque requirements
- Splash lubrication integral oil sump
- High strength ductile iron housing
- Six side mounting provision
- Centering boss for accurate face mounting
- Low backlash
- Compact construction
- High torque capacity
- High overhung load capacity
- Forward neutral or forward reverse option
- Straddle mounted pinions
- Full floating sun gear
- Hardened shafts, pinions, ring, and sun gear
- Forward neutral reverse shifter option for right angle transmission

## BENEFITS

- Minimizes power required for correction
- Minimizes maintenance
- 2 1/2 times strength of gray iron or aluminum
- Allows versatile mounting arrangements
- Allows easy shaft alignment
- Allows precise control
- Allows use in confined spaces
- High torque density for comparable unit volume
- Can be offset and pulley driven
- Gear box functions as engaged or disengaged unit
- Allows maximum rigidity
- Allows full load sharing of pinions
- Allows increased capacity in small volume
- Allows selection of relative input and output rotation

# SPECIFICATIONS

## OPERATING PRINCIPLES

Three basic transmissions comprise the CUBIC® Differential family of gear trains. They are:

- FT - Fairchild Three to One Transmission
- FRA - Fairchild Right Angle Transmission (Five available ratios)
- FHT - Fairchild One to One Transmission

All three transmissions are positive gear trains with two degrees of freedom. With primary input to either the "X" or "Y" shaft, output can be altered at the corresponding "Y" or "X" shaft by a secondary input applied to the "Z" shaft.

The FT series is the most basic of the three differential transmissions consisting of a simple epicyclic planetary gear configuration.

Primary input can be applied to the carrier ("X" shaft) or to the sun gear ("Y" shaft). The fixed speed ratio between the "X" and "Y" shafts is 3:1. When input is applied to the "X" shaft, the output speed correction ratio between the correction ("Z" shaft) and the output ("Y" shaft) is 43:1. Conversely, with the input applied to the "Y" shaft, the output speed correction ratio between the correction ("Z" shaft) and the output ("X" shaft) is 129:1.

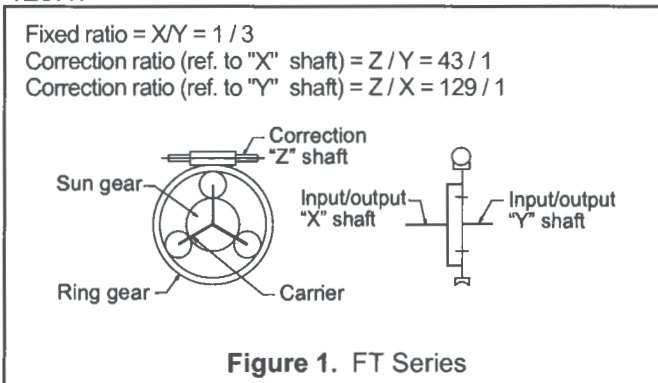

The FRA series consists of the FT series planetary with bevel gearing accessed to the sun gear.

Primary input can be applied to the carrier ("X" shaft) or to the bevel gear ("Y" shaft). The speed ratio between the "X" and "Y" shafts is 1:3 times the bevel gear ratio. When input is applied to the "X" shaft, the output speed correction ratio between the correction ("Z" shaft) and the output ("Y" shaft) is 43:1 times the bevel gear ratio. Conversely, with the input applied to the "Y" shaft, the output speed correction ratio between the correction ("Z" shaft) and the output ("X" shaft) is 129:1.

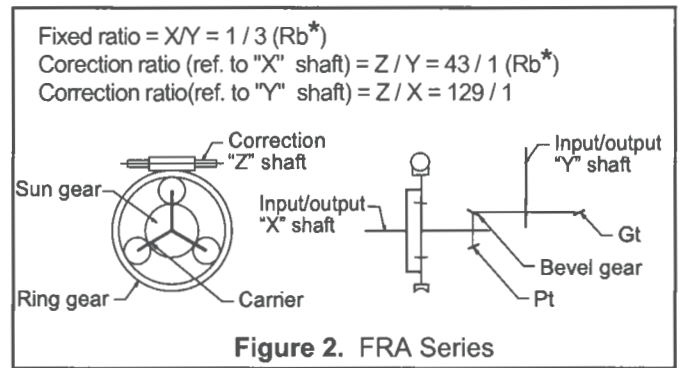

\*  $Rb = Gt/Pt$  (Gear Ratio)  
 $Gt = \text{No. of teeth in gear}$ ;  $Pt = \text{No. of teeth in pinion}$

You can equip the FRA series with FRS/FRN shifter options. The FRS option allows for forward, neutral and reverse relative rotation. The FRN option is forward and neutral only.

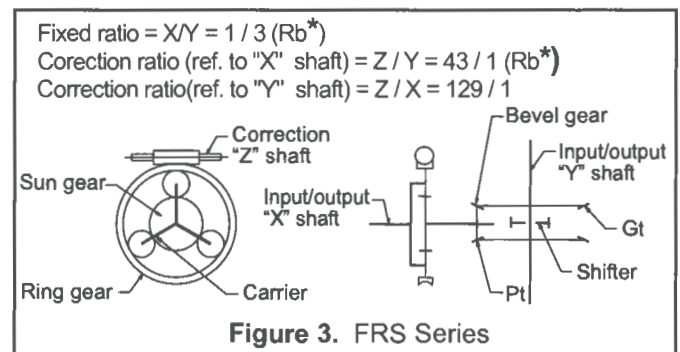

\*  $Rb = Gt/Pt$  (Bevel Gear Ratio)  
 $Gt = \text{No. of teeth in gear}$ ;  $Pt = \text{No. of teeth in pinion}$

The FHT series consists of two FT series planetaries coupled together with a common sun gear. One ring gear is fixed and the other ring gear is used as the correcting element.

Primary input can be applied to either the "X" shaft or to the "Y" shaft. The fixed speed ratio between the "X" and "Y" shafts is 1:1. The correction ratio relative to both the "X" and "Y" shaft is 129:1.

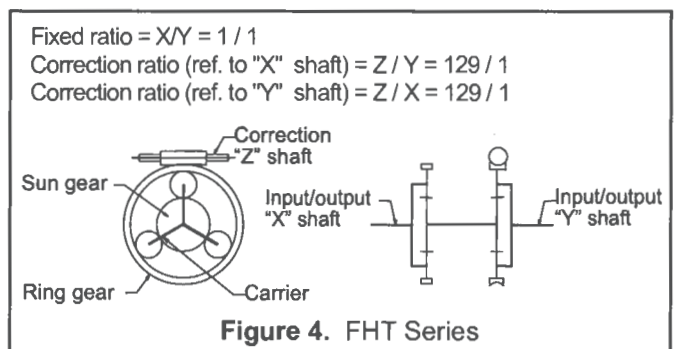

# GENERAL INFORMATION

**Table 1. Backlash - All Series**

Differential Size*	Backlash Input/Output (Static or Dynamic)	Backlash Correction/Output (Dynamic)
F ( )-01	less than 7 arcmin	less than 7 arcmin
F ( )-A1	less than 7 arcmin	less than 7 arcmin
F ( )-B1	less than 9 arcmin	less than 9 arcmin
F ( )-C1	less than 9 arcmin	less than 9 arcmin
F ( )-D1	less than 12 arcmin	less than 12 arcmin
F ( )-E1	less than 15 arcmin	less than 15 arcmin

One arcmin equals 1/60° equals 0.017°

\*Measured on planetary side of differential (X Shaft)

**Table 4. FT Series Max. Overhung Load**

Size	"X" Shaft	"Y" Shaft
FT-01	350 Pounds	120 Pounds
FT-A1	450 Pounds	150 Pounds
FT-B1	650 Pounds	220 Pounds
FT-C1	850 Pounds	285 Pounds
FT-D1	1050 Pounds	350 Pounds

Refer to the following tables below for maximum overhung load capacity:

**Table 2. FHT Series Max. Overhung Load**

Size	"X" Shaft	"Y" Shaft
FHT-01	350 Pounds	350 Pounds
FHT-A1	450 Pounds	450 Pounds
FHT-B1	650 Pounds	650 Pounds
FHT-C1	850 Pounds	850 Pounds
FHT-D1	1050 Pounds	1050 Pounds

**Table 3. FRA & FRS Series Max. Overhung Load**

Size	"X" Shaft	"Y" Shaft
FRA-01	350 Pounds	350 Pounds
FRA-OA	450 Pounds	350 Pounds
FRA-A1	450 Pounds	600 Pounds
FRA-AB	650 Pounds	600 Pounds
FRA-B1	650 Pounds	800 Pounds
FRA-BC	850 Pounds	800 Pounds
FRA-C1	850 Pounds	1100 Pounds
FRA-CD	1050 Pounds	1100 Pounds
FRA-D1	1050 Pounds	1600 Pounds
FRA-DE	1400 Pounds	1600 Pounds

**Table 5. Suggested Application Factors**

Power Source	Operating Hours per Day	Nature of Load		
		Uniform	Moderate Shock	Heavy Shock
Uniform	Intermittent 2 hrs.	1.00	1.10	1.50
	10 Hrs.	1.10	1.25	1.75
	24 Hrs.	1.50	1.75	2.00
Light Shock	Intermittent 2 hrs.	1.10	1.50	1.75
	10 Hrs.	1.50	1.75	2.00
	24 Hrs.	1.75	2.00	2.25
Medium Shock	Intermittent 2 hrs.	1.50	1.75	2.00
	10 Hrs.	1.75	2.00	2.25
	24 Hrs.	2.00	2.25	2.50

**Table 6. Temperatures**

AMBIENT TEMPERATURE	TEMPERATURE FACTOR
50° F	.9
70° F	1.0
90° F	1.1
105° F	1.2
120° F	1.4

REPAIR ONLY

# SPECIFICATIONS

## CAPACITIES AND RATINGS FT Series

Both shafts of the FT Series Differentials rotate in the same direction and either shaft may be used as the input to obtain either a 3:1 or 1:3 ratio. Rotation may be in either direction. One revolution of the correction shaft will rotate the low speed shaft 2.791 degrees or the high speed shaft 8.372 degrees. Correction ratio is either 129:1 or 43:1 depending on which shaft is selected as the output shaft.

If the X shaft (See Figure 8 on page 5) is at 0 (fixed),

turning the Z shaft 360 degrees will advance or retard the Y shaft 8.372 degrees.

Conversely, if the Y shaft is at 0 (fixed), turning the Z shaft 360 degrees will advance or retard the Y shaft 2.791 degrees.

Correction is unlimited in either direction and can be applied while the equipment is running or while it is stopped. Correction may be applied manually or through an integrally mounted correction motor.

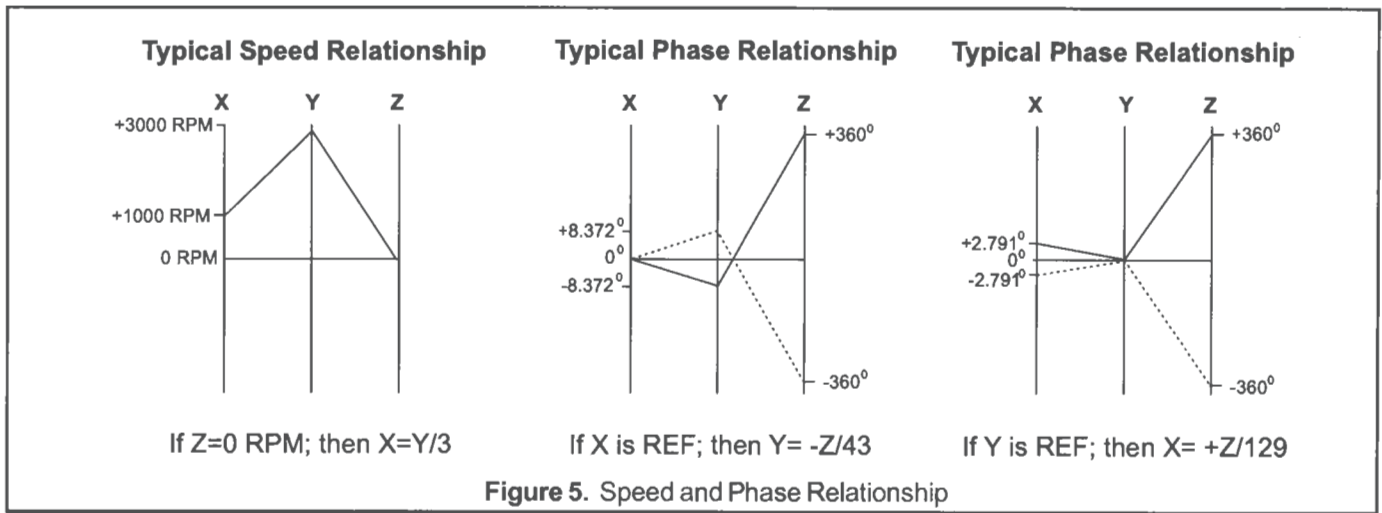

The CUBIC® Differential can also be used as a speed correcting device for accurately trimming line shaft speed. If the correction shaft is continuously driven by a variable speed element, the output shaft will be adjustable in speed as a function of the correction shaft speed. The accompanying speed nomograph shows the speed relationships of the different elements with an input

speed of 1000 rpm applied to the input shaft and 1290 revolutions per minute at the correction shaft. The correction shaft can be rotated in either direction to trim output speed above or below the normal value. The speed nomograph shows the results of a change in direction.

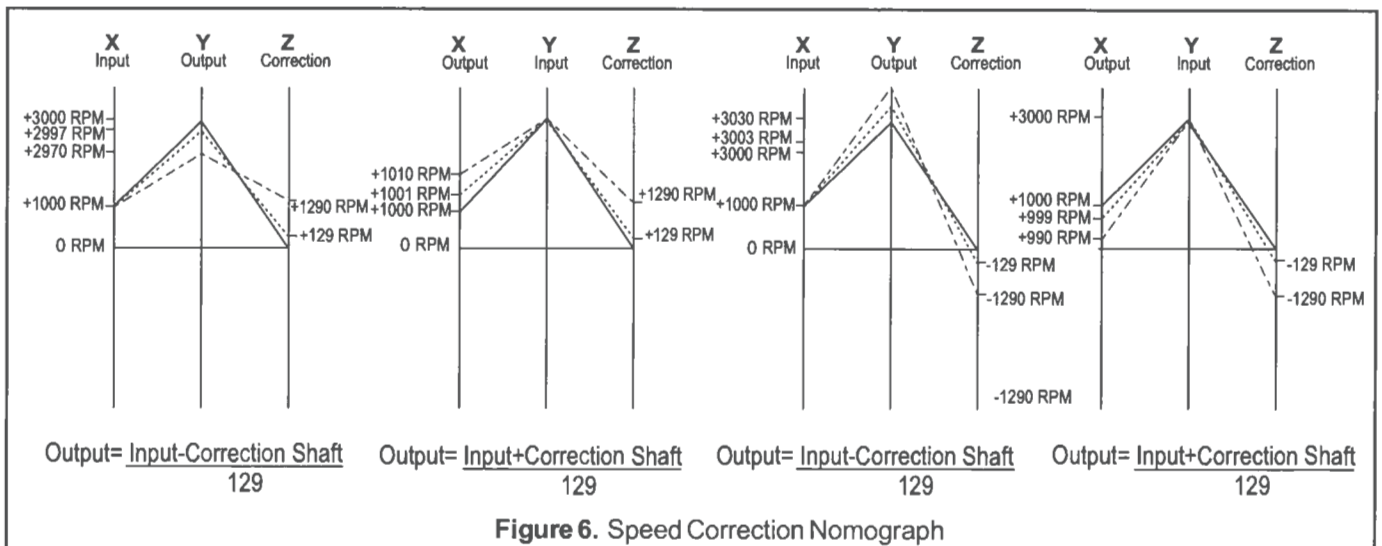

# ASSEMBLY ARRANGEMENTS

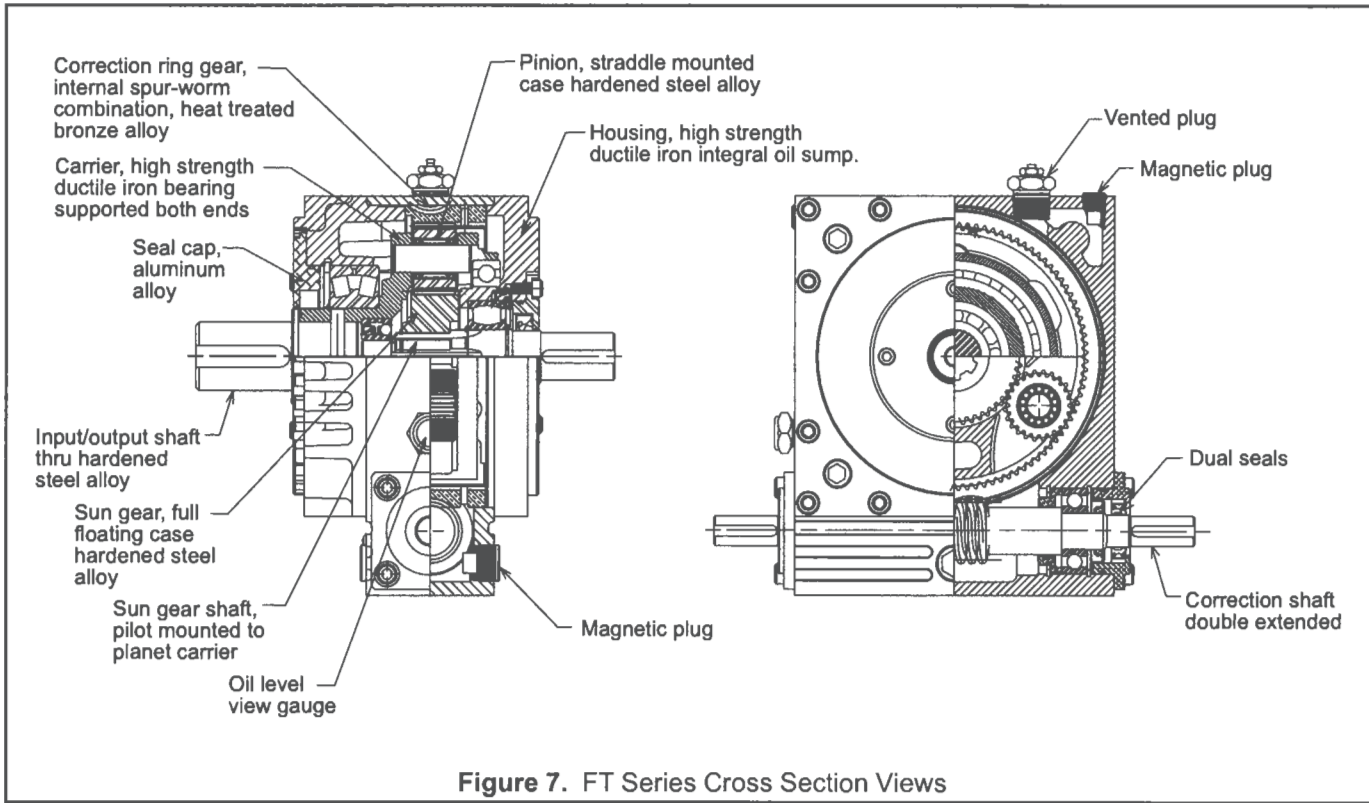

Figure 7. FT Series Cross Section Views

The FT Series of transmissions are splash lubricated. The design of these units permits mounting on either of six sides. However, if the input/output shaft is in any position other than horizontal, the customer must notify the factory when the order is placed so that special provisions can be made to satisfy lubrication requirements. When ordering, the customer should specify how the unit is to be mounted so that the drain plugs and view gage can be properly configured at the factory.

1. The assembled unit is composed of three separate zones.
2. Both ends (1 and 3) have tapped holes for pilot face mounting.

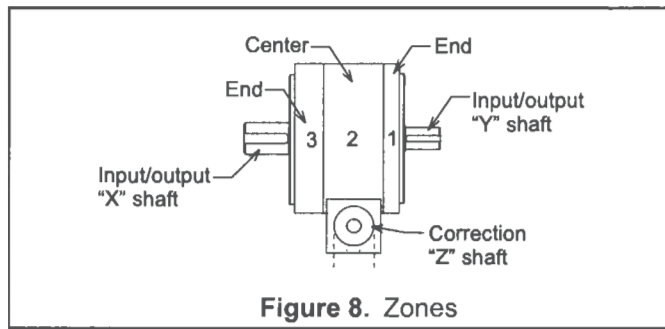

Figure 8. Zones

3. The center has four tapped holes on four sides for floor, wall and ceiling mounting. The transmission can be positioned (A) horizontal floor (B) vertical right (C) horizontal ceiling (D) vertical left.

Following are possible positions:

4. The required assembly is represented by the letters corresponding to the desired position of the transmission.
5. **Example:**  
Assembly (A) describes a unit with the correction shaft in the Horizontal Floor position.
6. **Example:**  
Assembly (D) describes a unit with the correction shaft in the Vertical Left position.

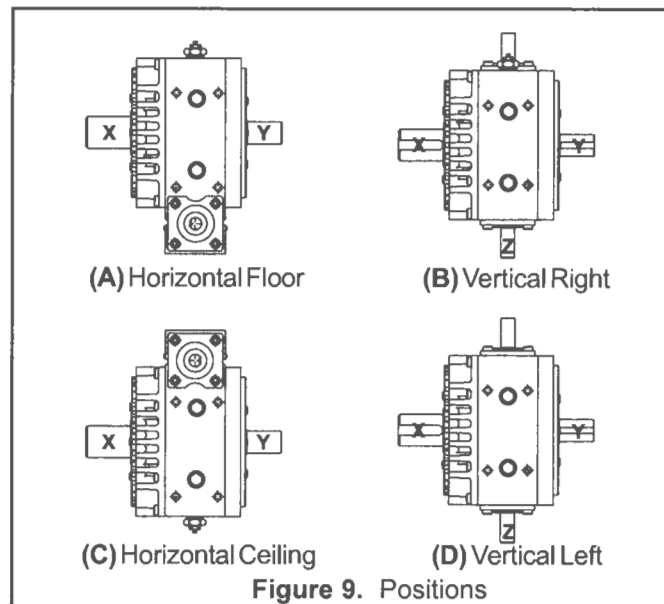

Figure 9. Positions

# OUTLINE DIMENSIONS

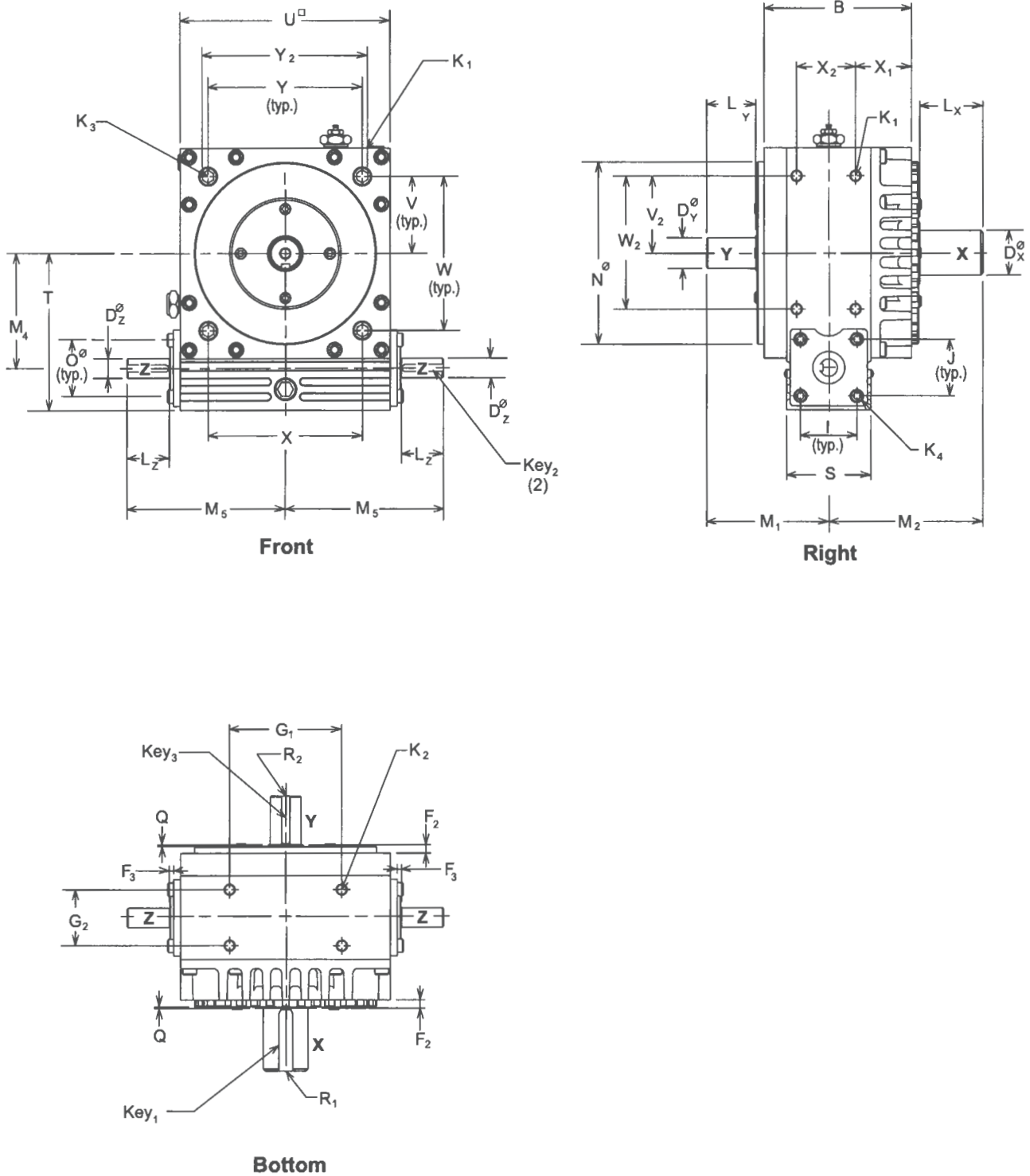

Figure 10. FT Series Outline Dimensions

**Table 7. FT Series Outline Dimensions**

SIZE	B	<sup>2</sup> D <sub>x</sub> <sub>4</sub>	<sup>2</sup> D <sub>y</sub> <sub>4</sub>	<sup>2</sup> D <sub>z</sub> <sub>4</sub>	F <sub>2</sub>	F <sub>3</sub>	G <sub>1</sub>	G <sub>2</sub>	I	J	K <sub>1</sub> K <sub>2</sub> K <sub>3</sub> K <sub>4</sub>	L <sub>x</sub>	L <sub>y</sub>	L <sub>z</sub>	M <sub>1</sub>	M <sub>2</sub>	M <sub>4</sub>	M <sub>5</sub>	<sup>1</sup> N
FT -01	3.46 88 MM	7/8 22 MM	5/8 16 MM	5/8 14 MM	.40 10 MM	.12 3 MM	3.150 80 MM	1.378 35 MM	1.590 40.4 MM	1.590 40.4 MM	1/4-20 5/16-18 5/16-18 1/4-20	1.378 35 MM	1.181 30 MM	1.181 30 MM	3.504 89 MM	2.953 75 MM	2.717 69 MM	1.378 35 MM	4.567 116 MM
FT -A1	4.13 105 MM	1 1/4 32 MM	7/8 22 MM	5/8 14 MM	.24 6 MM	.12 3 MM	3.150 80 MM	1.575 40 MM	1.590 40.4 MM	1.590 40.4 MM	5/16-18 5/16-18 5/16-18 1/4-20	1.772 45 MM	1.378 35 MM	1.181 30 MM	4.331 110 MM	3.425 87 MM	3.219 81.75 MM	1.378 35 MM	5.118 130 MM
FT -B1	4.61 117 MM	1 5/8 42 MM	1 1/4 32 MM	5/8 14 MM	.24 6 MM	.12 3 MM	3.150 80 MM	1.575 40 MM	1.590 40.4 MM	1.590 40.4 MM	3/8-16 3/8-16 3/8-16 1/4-20	2.362 60 MM	1.772 45 MM	1.181 30 MM	5.079 129 MM	4.134 105 MM	3.661 93 MM	1.772 45 MM	6.102 155 MM
FT -C1	5.00 127 MM	2 3/16 55 MM	1 5/8 42 MM	3/4 18 MM	.28 7 MM	.12 3 MM	3.740 95 MM	1.772 45 MM	1.860 47.2 MM	1.860 47.2 MM	1/2-13 3/8-16 1/2-13 1/4-20	3.346 80 MM	2.362 60 MM	1.181 30 MM	6.339 161 MM	4.921 125 MM	4.439 112.75 MM	1.772 45 MM	7.283 185 MM
FT -D1	5.91 150 MM	2 3/8 60 MM	1 15/16 50 MM	1 26 MM	.31 8 MM	.12 3 MM	5.512 140 MM	2.362 60 MM	2.259 57.38 MM	2.259 57.38 MM	1/2-13 3/8-16 1/2-13 1/4-20	3.740 95 MM	2.953 75 MM	1.772 45 MM	7.205 183 MM	6.024 153 MM	5.217 132.5 MM	2.362 60 MM	8.858 225 MM

SIZE	<sup>1</sup> O	Q	R <sub>1</sub> R <sub>2</sub>	S	T	U	V	V <sub>2</sub>	W	W <sub>2</sub>	X	X <sub>1</sub>	X <sub>2</sub>	Y	Y <sub>2</sub>	<sup>3</sup> KEY <sub>1</sub> <sub>4</sub>	<sup>3</sup> KEY <sub>2</sub> <sub>4</sub>	<sup>3</sup> KEY <sub>3</sub> <sub>4</sub>
FT -01	1.575 40 MM	.04 1 MM	5/16-18 1/4-20	2.36 60 MM	3.858 98 MM	4.921 125 MM	1.969 50 MM	1.969 50 MM	3.937 100 MM	3.346 85 MM	3.937 100 MM	1.417 36 MM	1.260 32 MM	3.937 100 MM	3.937 100 MM	3/16x3/16 6x6 MM	3/16x3/16 5x5 MM	3/16x3/16 5x5 MM
FT -A1	1.575 40 MM	.04 1 MM	3/8-16 5/16-18	2.36 60 MM	4.409 112 MM	5.906 150 MM	2.165 55 MM	2.165 55 MM	4.331 110 MM	3.740 95 MM	4.331 110 MM	1.575 40 MM	1.654 42 MM	4.331 110 MM	4.331 110 MM	1/4x1/4 10x8 MM	3/16x3/16 5x5 MM	3/16x3/16 6x6 MM
FT -B1	1.575 40 MM	.04 1 MM	1/2-13 3/8-16	2.36 60 MM	4.882 124 MM	6.693 170 MM	2.559 65 MM	2.559 65 MM	4.646 118 MM	4.646 118 MM	5.709 145 MM	2.047 52 MM	1.496 38 MM	5.709 145 MM	5.079 145 MM	3/8x3/8 12x8 MM	3/16x3/16 5x5 MM	1/4x1/4 10x8 MM
FT -C1	1.772 45 MM	.04 1 MM	5/8-11 1/2-13	2.76 70 MM	5.827 148 MM	8.268 210 MM	2.756 70 MM	2.756 70 MM	5.512 140 MM	5.512 140 MM	6.299 160 MM	1.969 50 MM	1.811 46 MM	6.299 160 MM	5.512 140 MM	1/2x1/2 16x10 MM	3/16x3/16 6x6 MM	3/8x3/8 12x8 MM
FT -D1	1.969 50 MM	.04 1 MM	5/8-11 1/2-13	3.35 85 MM	6.890 175 MM	10.236 260 MM	4.331 110 MM	3.937 100 MM	8.661 220 MM	6.693 170 MM	5.512 140 MM	2.244 57 MM	2.283 58 MM	5.512 140 MM	8.661 220 MM	5/8x5/8 18x11 MM	1/4x1/4 8x7 MM	1/2x1/2 14x9 MM

<sup>1</sup> Nominal Dimension. Tolerance Conforms to ANSI Class LC<sub>3</sub>  
<sup>2</sup> Nominal Dimension. Tolerance Conforms to ANSI Class LC<sub>1</sub>

<sup>3</sup> Keyseats Conform to ANSI Standard  
<sup>4</sup> Metric Shafts Standard. (English diameters optional)

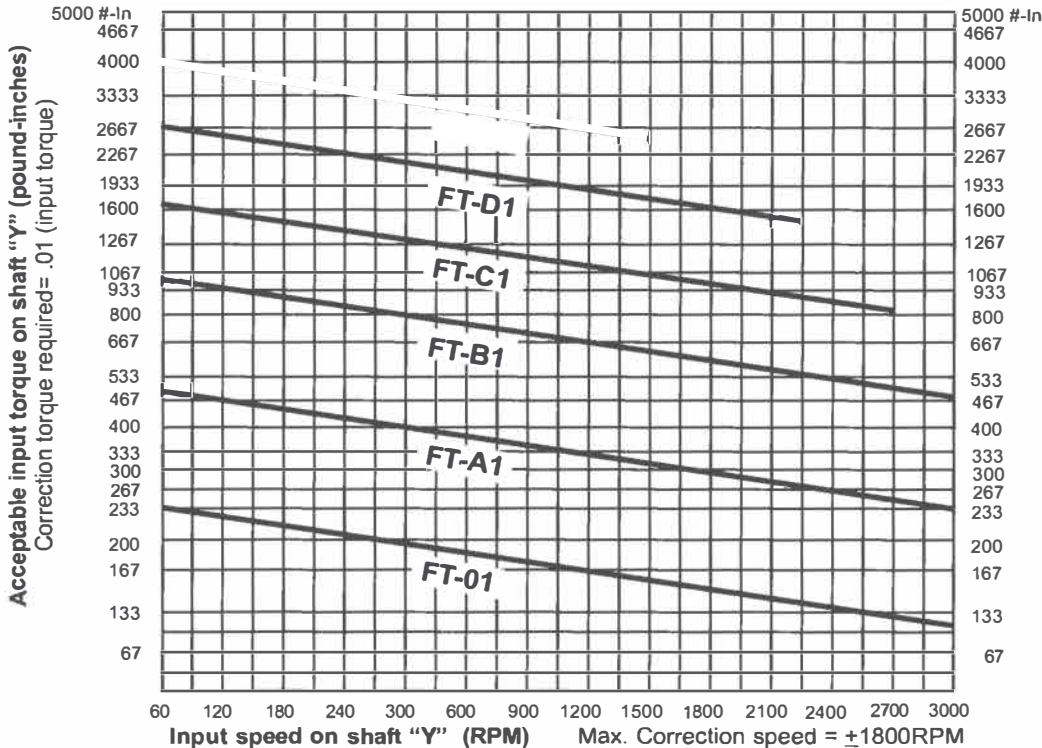

# SPECIFICATIONS

## CAPACITIES AND RATINGS FRA Series

Both shafts of the FRA Series Differentials may or may not rotate in the same direction. The relative rotation of the shafts depend on the bevel gear configuration (See Figure 18 on page 12).

The overall ratio and the correction ratio will depend on the bevel gear ratio. The correction ratio will also

depend on whether the input is applied to the X or the Y shaft (See Tables 9 and 10 on page 12). Correction is unlimited in either direction and can be applied while the equipment is running or while it is stopped. Correction may be applied manually or through an integrally mounted correction motor.

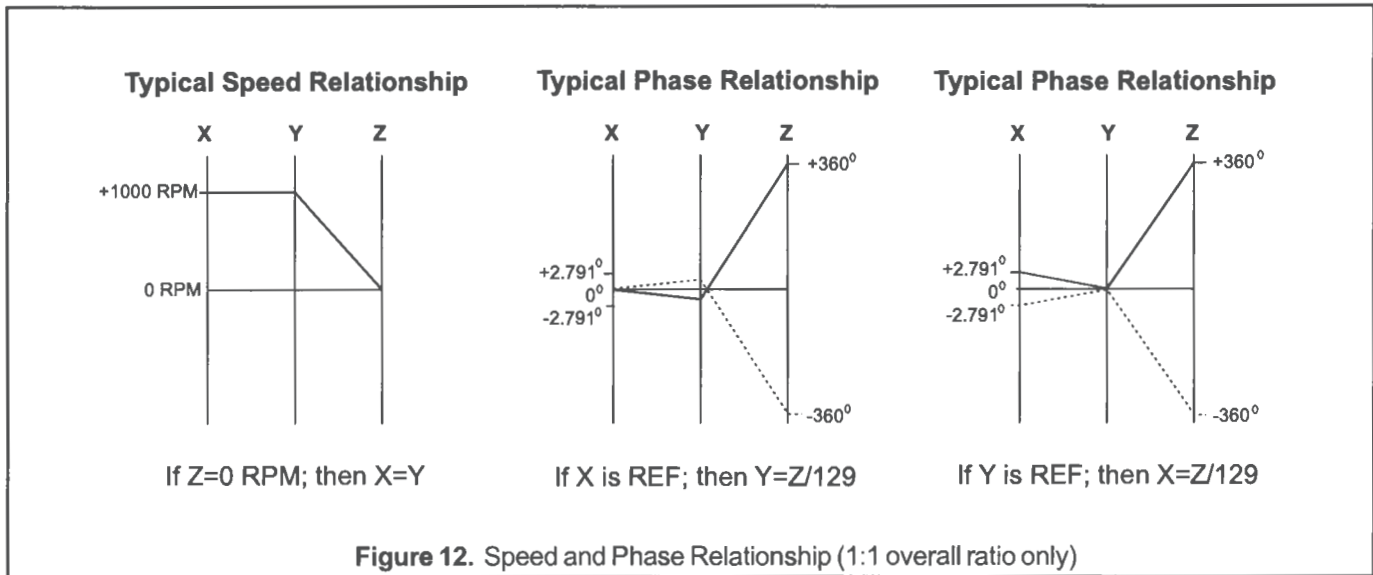

The CUBIC® Differential can also be used as a speed correcting device for accurately trimming line shaft speed. If the correction shaft is continuously driven by a variable speed element, the output shaft will be adjustable in speed as a function of the correction shaft speed. The accompanying speed nomograph shows the speed relationships of the different ele

ments with an input speed of 1000 rpm applied to the input shaft and 129 to 1290 revolutions per minute at the correction shaft. The correction shaft can be rotated in either direction to trim output speed above or below the normal value. The speed correction nomograph shows the results of a change in direction.

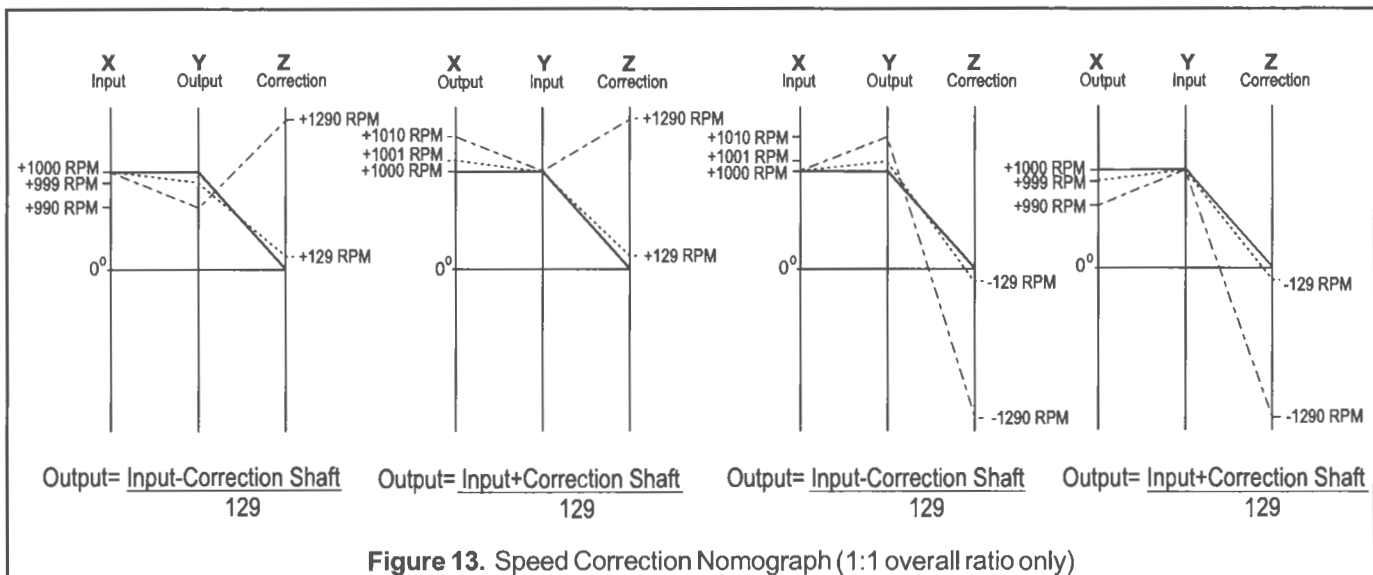



# ASSEMBLY ARRANGEMENTS

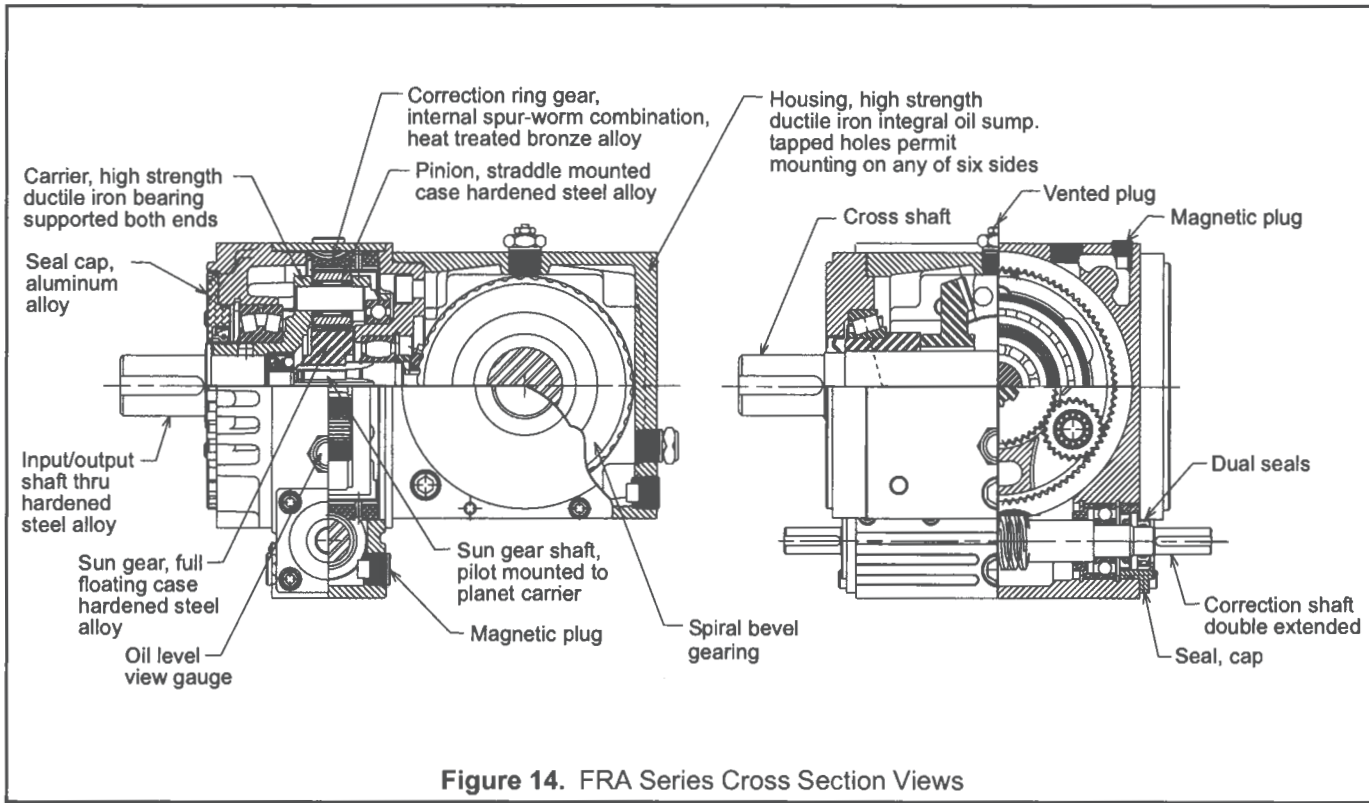

Figure 14. FRA Series Cross Section Views

The FRA Series of Transmissions are splash lubricated. The design of these units permits mounting on any of six sides. However, if the input/output shaft is in any position other than horizontal, the customer must notify the factory when the order is placed so that special provisions can be made to satisfy lubrication requirements. When ordering, the customer should specify how the unit is to be mounted so that the mounting holes, drain plugs, and view gage can be properly configured at the factory.

The customer should specify the mounting arrangements as follows:

1. The assembled unit is composed of three separate zones.

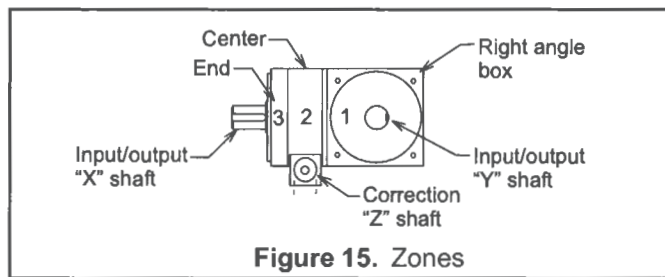

Figure 15. Zones

2. End (3) have tapped holes for pilot face mounting.
3. The center has four tapped holes on one side for floor, wall, or ceiling mounting. These four tapped holes are located on the correction shaft side of center housing.
4. Right angle box (1) has tapped holes in both ends for pilot face mounting and holes on the sides for floor, wall, or ceiling mounting.

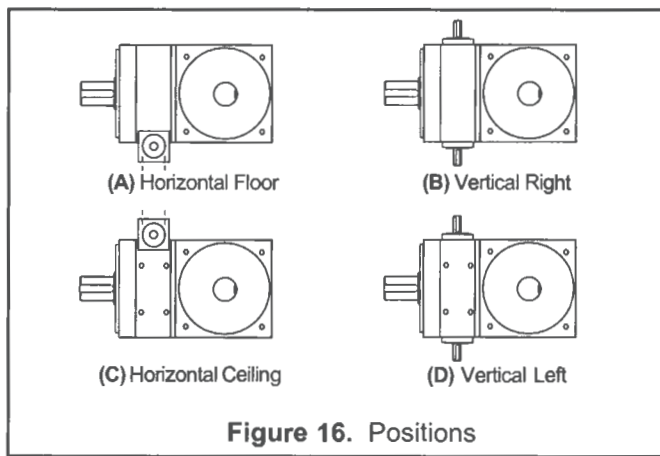

Figure 16. Positions

5. The relative position of the correction shaft can be (A) Horizontal floor, (B) Vertical right, (C) Horizontal ceiling, or (D) Vertical left.
6. Specify the desired assembly by identifying the position of the correction shaft in Figure 16 and the desired bevel gear arrangement in Figure 18 on page 12.
7. Example: Assembly AA describes a unit that has the correction shaft in the horizontal floor position and bevel gear arrangement A.
8. Example: Assembly CH describes a unit that has the correction shaft in the horizontal ceiling position and bevel gear arrangement H.

# OUTLINE DIMENSIONS

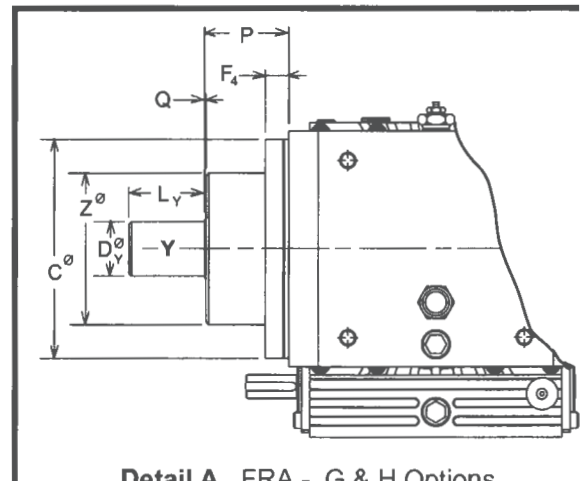
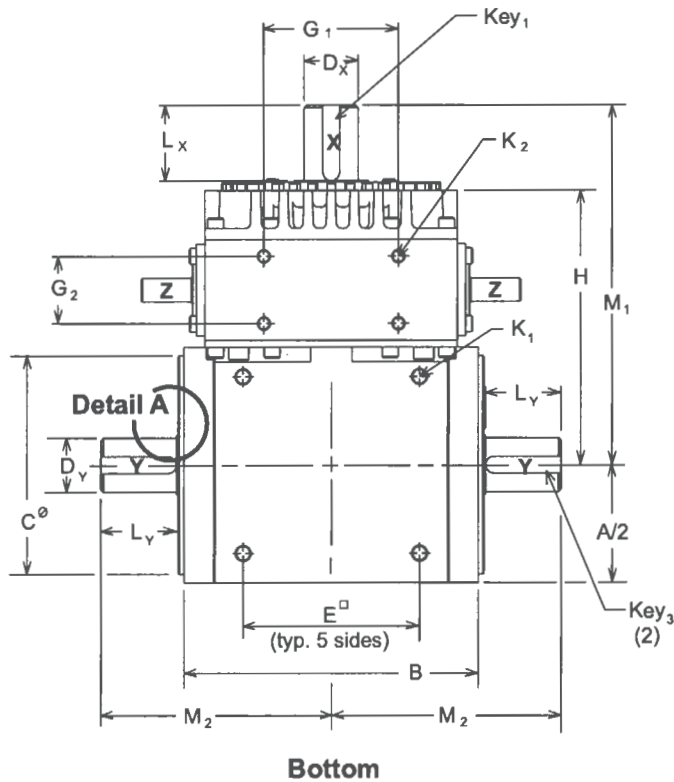
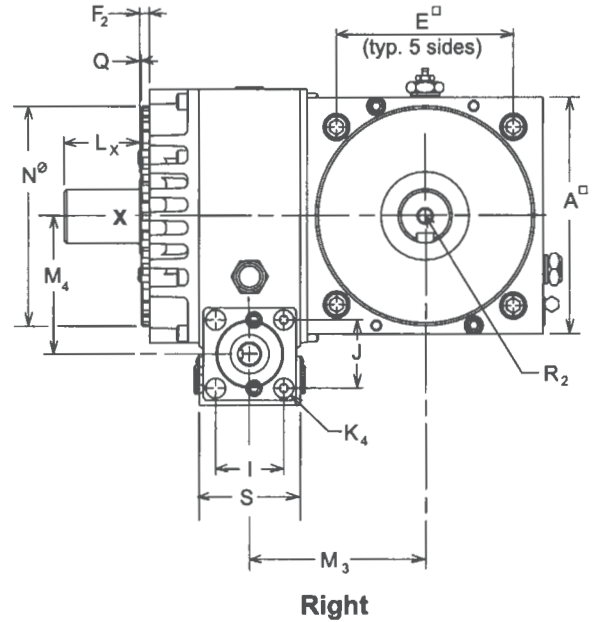
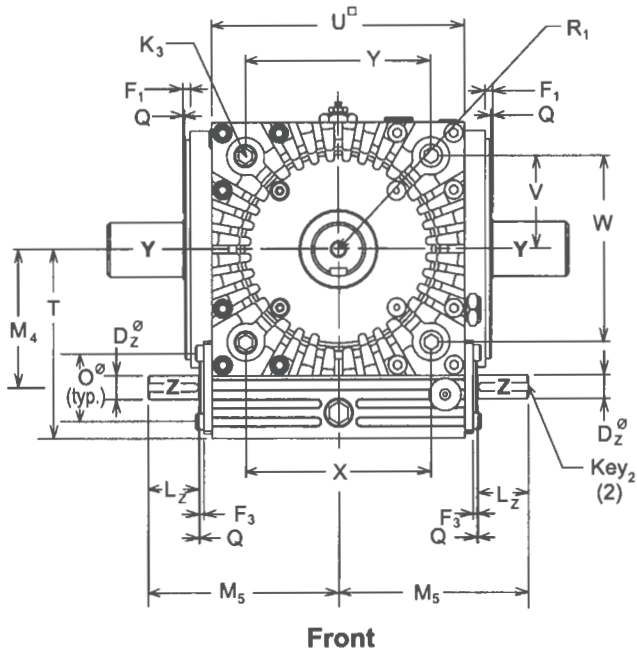

Figure 17. FRA Series Outline Dimensions

Detail A. FRA - G & H Options

**Table 8. FRA Series Outline Dimensions**

SIZE	A <sup>1</sup>	B	C	D <sub>x</sub> <sup>2</sup>	D <sub>y</sub> <sup>2</sup>	D <sub>z</sub> <sup>2</sup>	E <sup>1</sup>	F <sub>1</sub>	F <sub>2</sub>	F <sub>3</sub>	F <sub>4</sub>	G <sub>1</sub>	G <sub>2</sub>	H	I	J	K <sub>1</sub> K <sub>2</sub> K <sub>3</sub> K <sub>4</sub>	L <sub>x</sub>	L <sub>y</sub>	L <sub>z</sub>	M <sub>1</sub>
FRA-01	4.331 110 MM	5.709 145 MM	4.016 102 MM	7/8 22 MM	7/8 22 MM	5/8 14 MM	3.228 82 MM	.14 3.5 MM	.40 10 MM	.12 3 MM	.55 14 MM	3.150 80 MM	1.378 35 MM	5.08 129 MM	1.590 40.4 MM	1.590 40.4 MM	5/16-18 5/16-18 5/16-18 1/4-20	1.378 35 MM	1.378 35 MM	1.181 30 MM	6.85 174 MM
FRA-0A	4.331 110 MM	5.709 145 MM	4.016 102 MM	7/8 22 MM	7/8 22 MM	5/8 14 MM	3.228 82 MM	.14 3.5 MM	.24 6 MM	.12 3 MM	.55 14 MM	3.150 80 MM	1.575 40 MM	5.83 148 MM	1.590 40.4 MM	1.590 40.4 MM	5/16-18 5/16-18 5/16-18 1/4-20	1.378 35 MM	1.378 35 MM	1.181 30 MM	7.44 189 MM
FRA-A1	5.512 140 MM	6.890 175 MM	5.118 130 MM	1 1/4 32 MM	1 1/4 32 MM	5/8 14 MM	4.134 105 MM	.18 4.5 MM	.24 6 MM	.12 3 MM	.55 14 MM	3.150 80 MM	1.575 40 MM	6.42 163 MM	1.590 40.4 MM	1.590 40.4 MM	3/8-16 5/16-18 5/16-18 1/4-20	1.772 45 MM	1.772 45 MM	1.181 30 MM	8.43 214 MM
FRA-AB	5.512 140 MM	6.890 175 MM	5.118 130 MM	1 1/4 32 MM	1 1/4 32 MM	5/8 14 MM	4.134 105 MM	.18 4.5 MM	.24 6 MM	.12 3 MM	.55 14 MM	3.150 80 MM	1.575 40 MM	6.73 171 MM	1.590 40.4 MM	1.590 40.4 MM	3/8-16 3/8-16 3/8-16 1/4-20	1.772 45 MM	1.772 45 MM	1.181 30 MM	8.74 222 MM
FRA-B1	6.693 170 MM	8.465 215 MM	6.299 160 MM	1 5/8 42 MM	1 5/8 42 MM	5/8 14 MM	5.118 130 MM	.18 4.5 MM	.24 6 MM	.12 3 MM	.71 18 MM	3.150 80 MM	1.775 45 MM	7.32 186 MM	1.590 40.4 MM	1.590 40.4 MM	1/2-13 3/8-16 3/8-16 1/4-20	2.362 60 MM	2.362 60 MM	1.181 30 MM	9.92 252 MM
FRA-BC	6.693 170 MM	8.465 215 MM	6.299 160 MM	1 5/8 42 MM	1 5/8 42 MM	3/4 18 MM	5.118 130 MM	.18 4.5 MM	.24 6 MM	.12 3 MM	.71 18 MM	3.740 95 MM	1.772 45 MM	7.64 194 MM	1.860 47.24 MM	1.860 47.24 MM	1/2-13 3/8-16 1/2-13 1/4-20	2.362 60 MM	2.362 60 MM	1.181 30 MM	10.28 261 MM
FRA-C1	8.268 210 MM	10.236 260 MM	7.677 195 MM	2 3/16 55 MM	2 3/16 55 MM	3/4 18 MM	6.299 160 MM	.20 5 MM	.28 7 MM	.12 3 MM	.71 18 MM	3.400 86 MM	1.772 45 MM	8.43 214 MM	1.860 47.24 MM	1.860 47.24 MM	5/8-11 3/8-16 1/2-13 1/4-20	3.346 85 MM	3.346 85 MM	1.181 30 MM	12.05 306 MM
FRA-CD	8.268 210 MM	10.236 260 MM	7.677 195 MM	2 3/16 55 MM	2 3/16 55 MM	1 26 MM	8.299 160 MM	.20 5 MM	.31 8 MM	.12 3 MM	.71 18 MM	5.512 140 MM	2.362 60 MM	9.17 233 MM	2.259 57.38 MM	2.259 57.38 MM	5/8-11 3/8-16 1/2-13 1/4-20	3.346 85 MM	3.346 85 MM	1.772 45 MM	12.83 326 MM
FRA-D1	10.236 260 MM	12.992 330 MM	9.646 245 MM	2 3/8 60 MM	2 3/8 60 MM	1 26 MM	7.874 200 MM	.20 5 MM	.31 8 MM	.12 3 MM	.91 23 MM	5.512 140 MM	2.362 60 MM	10.16 258 MM	2.259 57.38 MM	2.480 83 MM	5/8-11 3/8-16 1/2-13 1/4-20	3.740 95 MM	3.740 95 MM	1.772 45 MM	14.21 361 MM
FRA-DE	10.236 260 MM	12.992 330 MM	9.646 245 MM	2 3/8 60 MM	2 3/8 60 MM	1 1/4 32 MM	7.874 200 MM	.20 5 MM	.35 9 MM	.12 3 MM	.91 23 MM	7.087 180 MM	2.362 60 MM	10.59 269 MM	2.520 64 MM	2.520 64 MM	3/4-10 3/8-16 3/4-10 1/4-20	3.740 95 MM	3.740 95 MM	1.772 45 MM	14.69 373 MM

SIZE	M <sub>2</sub>	M <sub>3</sub>	M <sub>4</sub>	M <sub>5</sub>	N <sup>1</sup>	O <sup>1</sup>	P	Q	R <sub>1</sub> R <sub>2</sub>	S	T	U <sup>2</sup>	V	W	X	Y	Z	KEY <sub>1</sub> <sup>3</sup>	KEY <sub>2</sub> <sup>3</sup>	KEY <sub>3</sub> <sup>3</sup>
FRA-01	4.37 111 MM	3.346 85 MM	2.717 69 MM	3.95 100 MM	4.5669 116 MM	1.575 40 MM	1.77 45 MM	.04 1 MM	5/16-18 5/16-18	2.36 60 MM	3.858 98 MM	4.921 125 MM	1.969 50 MM	3.937 100 MM	3.937 100 MM	3.937 100 MM	2.756 70 MM	3/16x3/16 6x6 MM	3/16x3/16 5x5 MM	3/16x3/16 6x6 MM
FRA-0A	4.37 111 MM	3.504 89 MM	3.219 81.75 MM	4.45 113 MM	5.1180 113 MM	1.575 40 MM	1.77 45 MM	.04 1 MM	5/16-18 5/16-18	2.36 60 MM	4.409 112 MM	5.906 150 MM	2.165 55 MM	4.331 110 MM	4.331 110 MM	4.331 110 MM	2.756 70 MM	1/4x1/4 10x8 MM	3/16x3/16 5x5 MM	3/16x3/16 6x6 MM
FRA-A1	5.39 137 MM	4.094 104 MM	3.219 81.75 MM	4.45 113 MM	5.118 113 MM	1.575 40 MM	1.97 50 MM	.04 1 MM	3/8-16 3/8-16	2.36 60 MM	4.409 112 MM	5.906 150 MM	12.165 55 MM	4.331 110 MM	4.331 110 MM	4.331 110 MM	3.543 90 MM	1/4x1/4 10x8 MM	3/16x3/16 5x5 MM	1/4x1/4 10x8 MM
FRA-AB	5.39 137 MM	4.252 108 MM	3.661 93 MM	4.84 123 MM	6.1024 55 MM	1.575 40 MM	1.97 50 MM	.04 1 MM	1/2-13 3/8-16	2.36 60 MM	4.882 124 MM	6.693 170 MM	2.559 65 MM	4.646 118 MM	3.740 95 MM	5.709 145 MM	3.543 90 MM	3/8x3/8 12x8 MM	3/16x3/16 5x5 MM	1/4x1/4 10x8 MM
FRA-B1	6.77 172 MM	4.843 123 MM	3.661 93 MM	4.84 123 MM	6.1024 55 MM	1.575 40 MM	2.56 65 MM	.04 1 MM	1/2-13 1/2-13	2.36 60 MM	4.882 124 MM	6.693 170 MM	2.559 65 MM	4.646 118 MM	5.709 145 MM	5.709 145 MM	4.331 110 MM	3/8x3/8 12x8 MM	3/16x3/16 5x5 MM	3/8x3/8 12x8 MM
FRA-BC	6.77 172 MM	4.921 125 MM	4.439 112.75 MM	5.63 143 MM	7.2835 185 MM	1.772 45 MM	3.35 85 MM	.04 1 MM	1/2-13 1/2-13	2.76 70 MM	5.827 148 MM	8.268 210 MM	2.756 70 MM	5.512 140 MM	6.299 160 MM	6.299 160 MM	4.331 110 MM	1/2x1/2 16x10 MM	3/16x3/16 6x6 MM	3/8x3/8 12x8 MM
FRA-C1	8.66 220 MM	5.709 145 MM	4.439 112.75 MM	5.63 143 MM	7.2835 185 MM	1.772 45 MM	3.35 85 MM	.04 1 MM	5/8-11 5/8-11	2.76 70 MM	5.827 148 MM	8.268 210 MM	2.756 70 MM	5.512 140 MM	6.299 160 MM	6.299 160 MM	5.315 135 MM	1/2x1/2 16x10 MM	3/16x3/16 6x6 MM	1/2x1/2 16x10 MM
FRA-CD	8.66 220 MM	6.024 153 MM	5.217 132.5 MM	7.20 183 MM	8.8583 225 MM	1.969 50 MM	3.35 85 MM	.04 1 MM	5/8-11 5/8-11	3.35 85 MM	6.890 175 MM	10.236 260 MM	4.331 110 MM	8.662 220 MM	5.512 140 MM	5.512 140 MM	5.315 135 MM	5/8x5/8 18x11 MM	1/4x1/4 8x7 MM	1/2x1/2 16x10 MM
FRA-D1	10.43 265 MM	7.008 178 MM	5.217 132.5 MM	7.20 183 MM	8.8583 225 MM	1.969 50 MM	4.33 110 MM	.04 1 MM	5/8-11 5/8-11	3.35 85 MM	6.890 175 MM	10.236 260 MM	4.331 110 MM	8.662 220 MM	5.512 140 MM	5.512 140 MM	5.906 150 MM	5/8x5/8 18x11 MM	1/4x1/4 8x7 MM	5/8x5/8 18x11 MM
FRA-DE	10.43 265 MM	7.165 182 MM	6.496 165 MM	8.58 218 MM	11.4173 290 MM	2.362 60 MM	4.33 110 MM	.04 1 MM	3/4-10 3/4-10	3.54 90 MM	8.268 210 MM	12.992 330 MM	5.906 150 MM	11.811 300 MM	5.512 140 MM	5.512 140 MM	5.906 150 MM	5/8x5/8 18x11 MM	3/8x3/8 10x8 MM	5/8x5/8 10x11 MM

<sup>1</sup> Nominal Dimension. Tolerance Conforms to ANSI Class LC<sub>3</sub>      <sup>3</sup> Keyseats Conform to ANSI Standard

<sup>2</sup> Nominal Dimension. Tolerance Conforms to ANSI Class LC<sub>1</sub>      <sup>4</sup> Metric Shafts Standard. (English diameters optional)

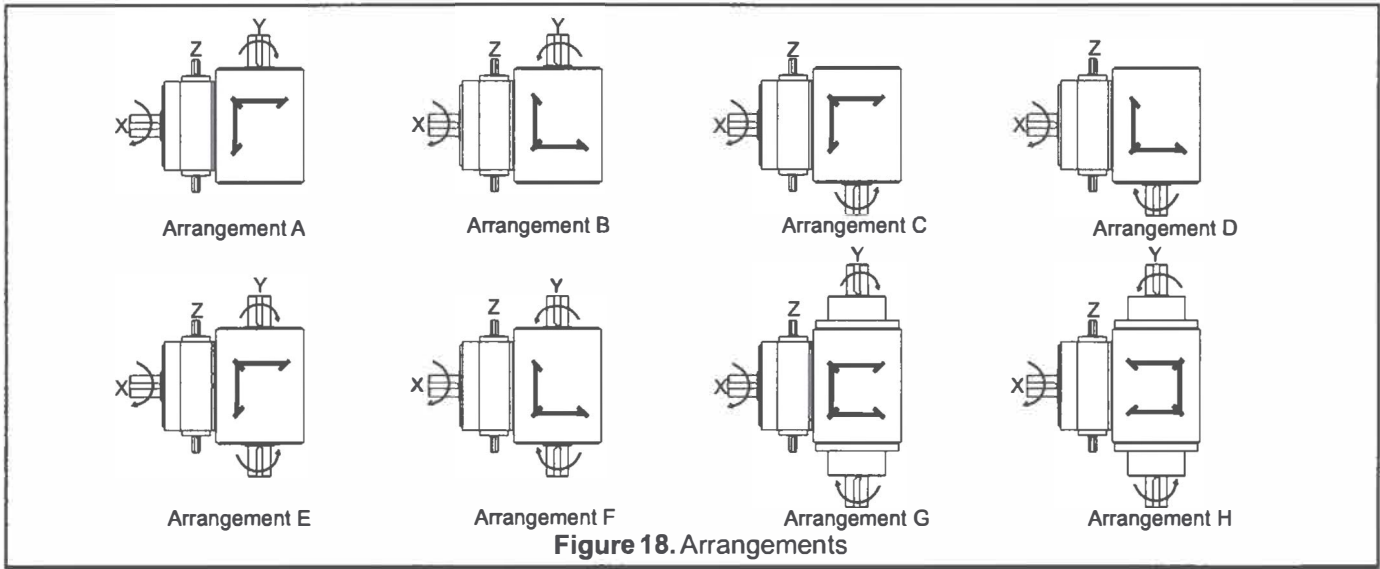

**Table 9. Ratio/Speed Chart. Input to Planetary**  
 Example: 1000RPM input to planetary "X" shaft  
 + 1800 RPM correction @ "Z" shaft  
 Output @ right angle box "Y" shaft

Overall Ratio Input: output	1:3	1:2.25	1:2	1:1.5	1:1*
Output Speed rpm	3000	2250	2000	1500	1000
Correction Ratio Input: output	43:1	57.33:1	64.5:1	86:1	129:1
Corrected Output Speed rpm	+41.86	+31.40	+29.91	+20.93	+13.95

\*Not available for FRS-FRN option

**Table 10. Ratio/Speed Chart. Input to Right Angle Box**  
 Example: 1000RPM input to planetary "Y" shaft  
 ± 1800 RPM correction @ "Z" shaft  
 Output @ right angle box "X" shaft

Overall Ratio Input: output	1:1*	1.5:1	2:1	2.25:1	3:1
Output Speed rpm	1000	666.67	500	444.44	333.33
Correction Ratio Input: output	129:1	129:1	129:1	129:1	129:1
Corrected Output Speed rpm	±13.95	±13.95	±13.95	±13.95	±13.95

Note: Other arrangements are available. If the required assembly is not shown, the customer should supply an application sketch.

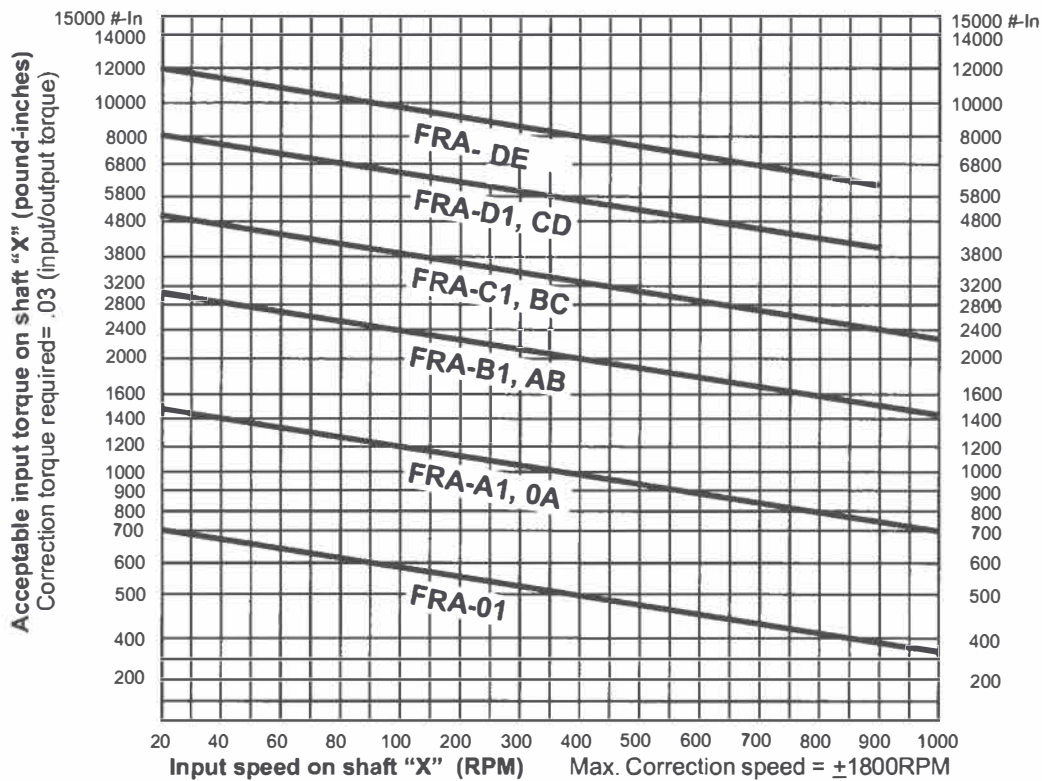

## FRA OPTIONS

An option is available for the FRA Series of Transmissions. When equipped with the option, the Series is called FRS (Forward Neutral Reverse Shifter) or FRN (Forward Neutral or Reverse Neutral). Outline dimensions for the option are the same as for the FRA Series of Transmissions. Table 5 shows the shifter envelope for each size together with shifting handle height and length. Available input/output ratios for the option are shown in Ratio Tables 9 and 10 on page 12 and Table 12 below.

The FRS shifter can be placed in any of three positions, (Forward, Neutral, Reverse).

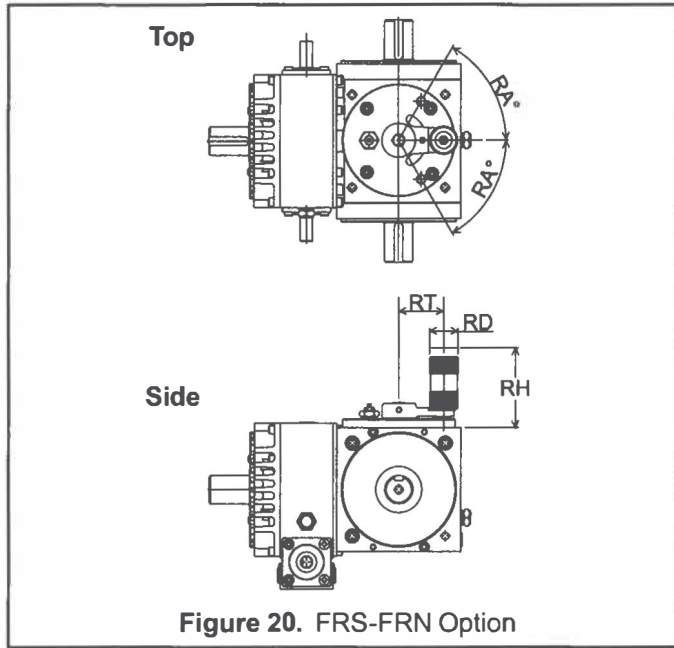

Figure 20. FRS-FRN Option

The FRN shifter can be placed in any of two positions, (Forward Neutral) or (Reverse Neutral).

Figure 27 shows the FRA unit with the shifter mounted in each of three positions with respect to the Right Angle Box.

TR - Top Rear  
TF - Top Forward  
EU - End Up

Size	RA <sup>0</sup>	RD	RH	RT
FRS -01	60°	1 1/4	3 1/2	1.53
FRS -OA	60°	1 1/4	3 1/2	1.53
FRS -A1	60°	1 1/4	3 1/2	2.00
FRS -AB	60°	1 1/4	3 1/2	2.00
FRS -B1	60°	1 1/4	3 1/2	2.53
FRS -BC	60°	1 1/4	3 1/2	2.53
FRS -C1	60°	1 1/4	3 1/2	2.53
FRS -CD	60°	1 1/4	3 1/2	2.53
FRS -D1	60°	1 1/4	3 1/2	4.00
FRS -DE	60°	1 1/4	3 1/2	4.00

Ratio/Speed	Input to right angle box
Ratio	1.5:1
	2:1
	2.25:1
	3:1

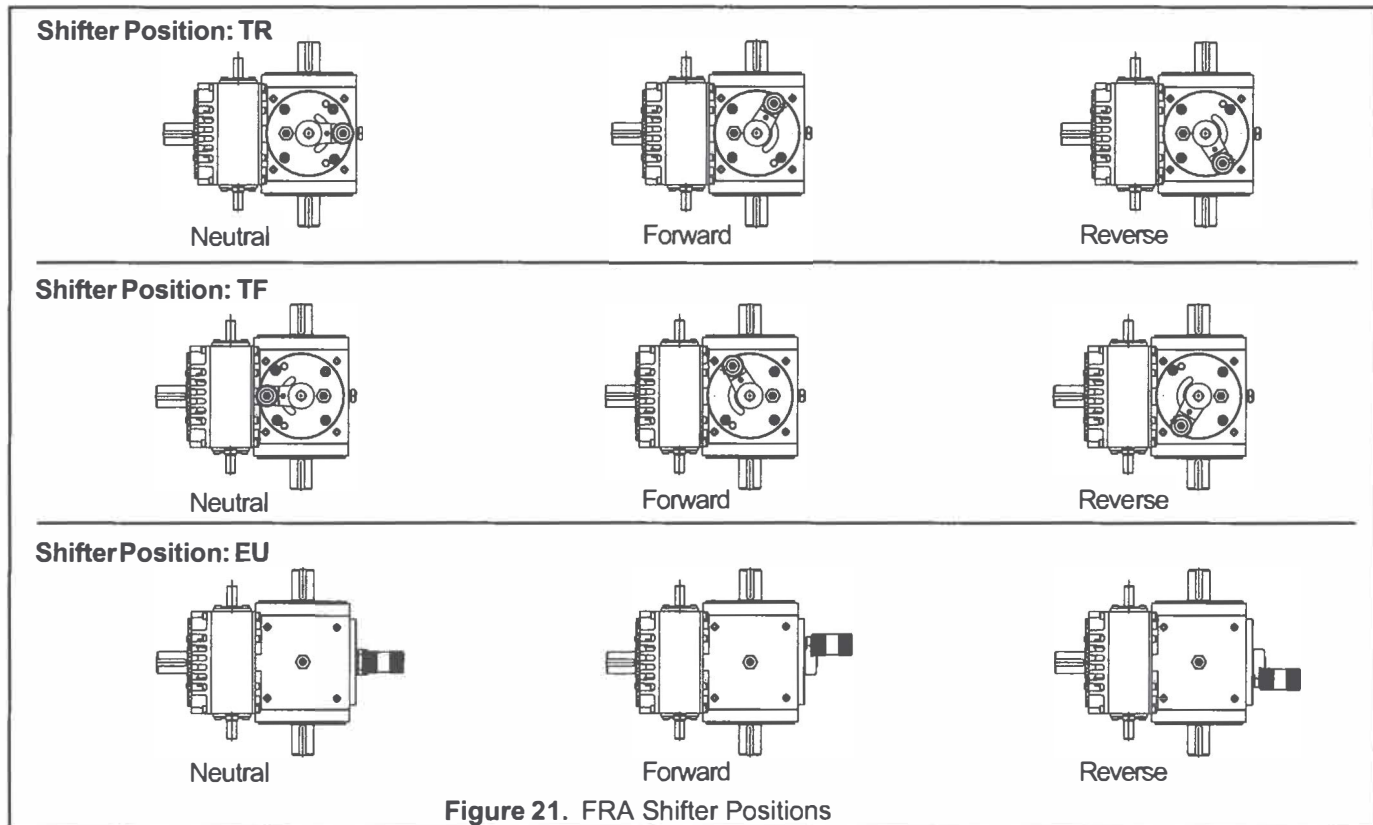

Figure 21. FRA Shifter Positions

# OUTLINE DIMENSIONS

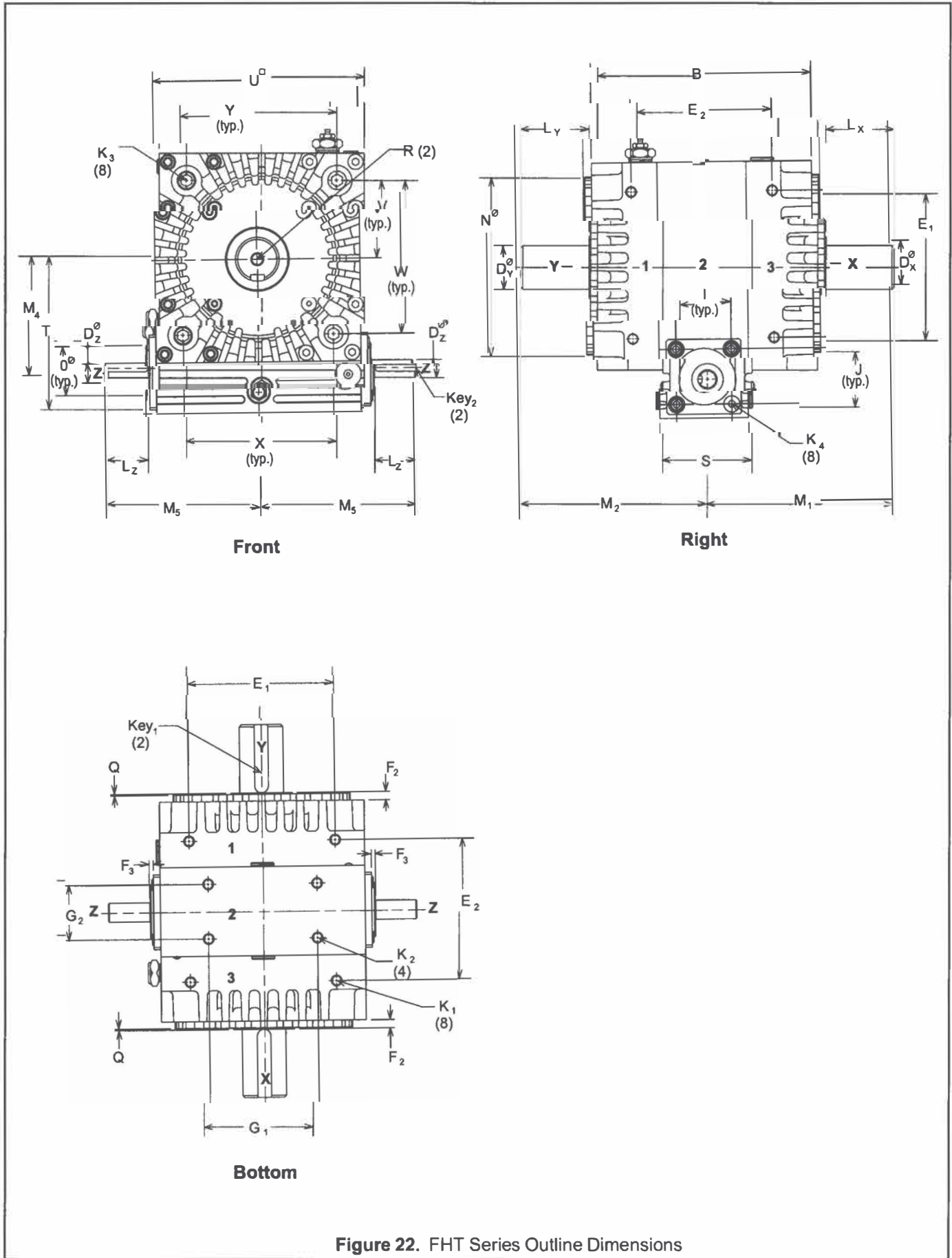

Figure 22. FHT Series Outline Dimensions

**Table 13. FHT Series Outline Dimensions**

SIZE	B	<sup>2</sup> D <sub>x</sub> 4	<sup>2</sup> D <sub>y</sub> 4	<sup>2</sup> D <sub>z</sub>	E <sub>1</sub>	E <sub>2</sub>	F <sub>2</sub>	F <sub>3</sub>	G <sub>1</sub>	G <sub>2</sub>	I	J	K <sub>1</sub> K <sub>2</sub> K <sub>3</sub> K <sub>4</sub>	L <sub>x</sub>	L <sub>y</sub>	L <sub>z</sub>	M <sub>1</sub>
FHT-01	5.50 140MM	7/8 22MM	7/8 22MM	5/8 14MM	3.232 82MM	3.444 87MM	.36 9MM	.12 3MM	3.150 80MM	1.378 35MM	1.590 40.4MM	1.590 40.4MM	5/16-18 5/16-18 1/4-20	1.42 36MM	1.42 36MM	1.18 30MM	4.53 115MM
FHT-A1	6.34 161MM	1 1/4 32MM	1 1/4 32MM	5/8 14MM	4.220 107MM	4.062 103MM	.24 6MM	.12 3MM	3.150 80MM	1.575 40MM	1.590 40.4MM	1.590 40.4MM	5/16-18 5/16-18 1/4-20	1.97 50MM	1.97 50MM	1.18 30MM	5.38 137MM
FHT-B1	7.32 186MM	1 5/8 42MM	1 5/8 42MM	5/8 14MM	5.000 127MM	4.376 111MM	.24 6MM	.12 3MM	3.150 80MM	1.575 40MM	1.590 40.4MM	1.590 40.4MM	3/8-16 3/8-16 1/4-20	2.36 60MM	2.36 60MM	1.18 30MM	6.26 159MM
FHT-C1	8.35 212MM	2 3/16 55MM	2 3/16 55MM	3/4 18MM	6.582 167MM	5.000 127MM	.28 7MM	.12 3MM	3.740 95MM	1.772 45MM	1.860 47.2MM	1.860 47.2MM	3/8-16 1/2-13 1/4-20	3.35 85MM	3.35 85MM	1.18 30MM	7.80 198MM
FHT-D1	9.53 242MM	2 3/8 60MM	2 3/8 60MM	1 26MM	8.548 217MM	5.626 143MM	.28 7MM	.12 3MM	5.512 140MM	2.362 60MM	2.259 57.4MM	2.259 57.4MM	3/8-16 1/2-13 1/4-20	3.74 95MM	3.74 95MM	1.77 45MM	8.78 223MM

SIZE	M <sub>2</sub>	M <sub>4</sub>	M <sub>5</sub>	<sup>1</sup> N	<sup>1</sup> O	Q	R	S	T	U	V	W	X	Y	<sup>3</sup> KEY <sub>1</sub> 4	<sup>3</sup> KEY <sub>2</sub> 4
FHT-01	4.53 115MM	2.717 69MM	3.95 100MM	4.5669 116MM	1.575 40MM	.04 1MM	5/16-18	2.36 60MM	3.858 98MM	4.921 125MM	1.969 50MM	3.937 100MM	3.937 100MM	3.937 100MM	3/16x3/16 6x6MM	3/16x3/16 5x5MM
FHT-A1	5.38 137MM	3.129 81.75MM	4.45 113MM	5.1180 130MM	1.575 40MM	.04 1MM	3/8-16	2.57 65MM	4.409 112MM	5.906 150MM	2.165 55MM	4.331 110MM	4.331 110MM	4.331 110MM	1/4x1/4 10x8MM	3/16x3/16 5x5MM
FHT-B1	6.26 159MM	3.661 93MM	4.84 123MM	6.1024 155MM	1.575 40MM	.04 1MM	1/2-13	2.57 65MM	4.882 124MM	6.693 170MM	2.559 65MM	4.646 118MM	5.709 145MM	5.709 145MM	3/8x3/8 12x8MM	3/16x3/16 5x5MM
FHT-C1	7.80 198MM	4.439 112.75MM	5.63 143MM	7.2835 185MM	1.772 45MM	.04 1MM	5/8-11	2.96 75MM	5.827 148MM	8.268 210MM	2.756 70MM	5.512 140MM	6.299 160MM	6.299 160MM	1/2x1/2 16x10MM	3/16x3/16 6x6MM
FHT-D1	8.78 223MM	5.217 132.5MM	7.20 183MM	8.8583 225MM	1.969 50MM	.04 1MM	5/8-11	3.54 90MM	6.890 175MM	10.236 260MM	4.331 110MM	8.622 220MM	5.512 140MM	5.512 140MM	5/8x5/8 18x11MM	1/4x1/4 8x7MM

<sup>1</sup> Nominal Dimension. Tolerance conforms to ANSI class LC<sub>3</sub>

<sup>2</sup> Nominal Dimension. Tolerance conforms to ANSI class LC<sub>1</sub>

<sup>3</sup> Keyseats conform to ANSI standard

<sup>4</sup> Metric shafts standard. (English diameters optional)

# SPECIFICATIONS

## CAPACITIES AND RATINGS FHT Series

Both shafts of the FHT Series Differential rotate in the same direction and either shaft may be used as the input shaft to obtain a 1:1 ratio. Rotation may be in either direction. One revolution of the correction shaft will rotate the output shaft 2.791°. Correction ratio is 129:1; therefore, 129 turns of the correction shaft will rotate the output shaft through one revolution. If the X shaft is at 0 (fixed) turning the Z shaft 360° will advance or retard the Y shaft

2.791°. Conversely, if the Y shaft is at 0 (fixed) turning the Z shaft 360° will advance or retard the X shaft 2.791° (see phase relationship for relative rotation).

Correction is unlimited in either direction and can be applied while the equipment is running or while it is stopped. Correction may be applied manually or through an integrally mounted correction motor.

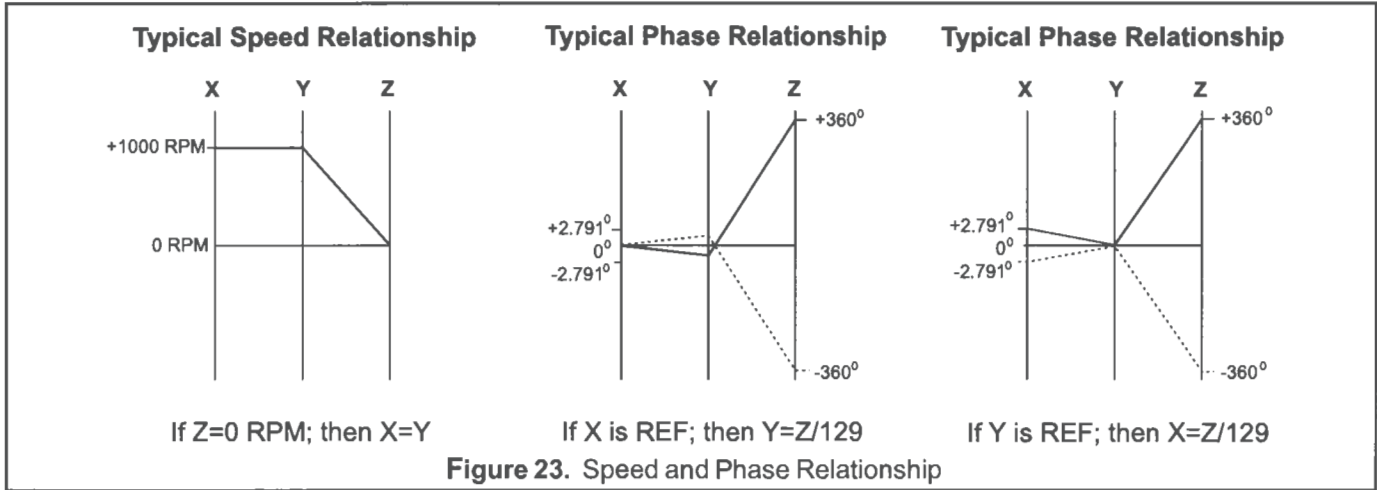

The FHT Series Differential can also be used as a speed correcting device for accurately trimming line shaft speed. If the correction shaft is continuously driven by a variable speed element, the output shaft will be adjustable in speed as a function of the correction shaft speed. The accompanying speed connection nomograph shows the speed relationships of the different elements with an input speed of 1000 rpm applied to the input shaft and 129 to 1290 revolutions per minute at the correction shaft. The correction shaft can be rotated in either direction to trim output speed above or below the normal value. The speed

connection nomograph shows the results of a change in direction.

The FHT Series of transmissions are splash lubricated. The design of these units permits mounting on any of six sides. However, if the input/output shaft is in any position other than horizontal, the customer must notify the factory when ordering so that special provisions can be made to satisfy lubrication requirements. When ordering, the customer should specify how the unit is to be mounted so that the mounting holes, drain plugs, and view gage can be properly configured at the factory.

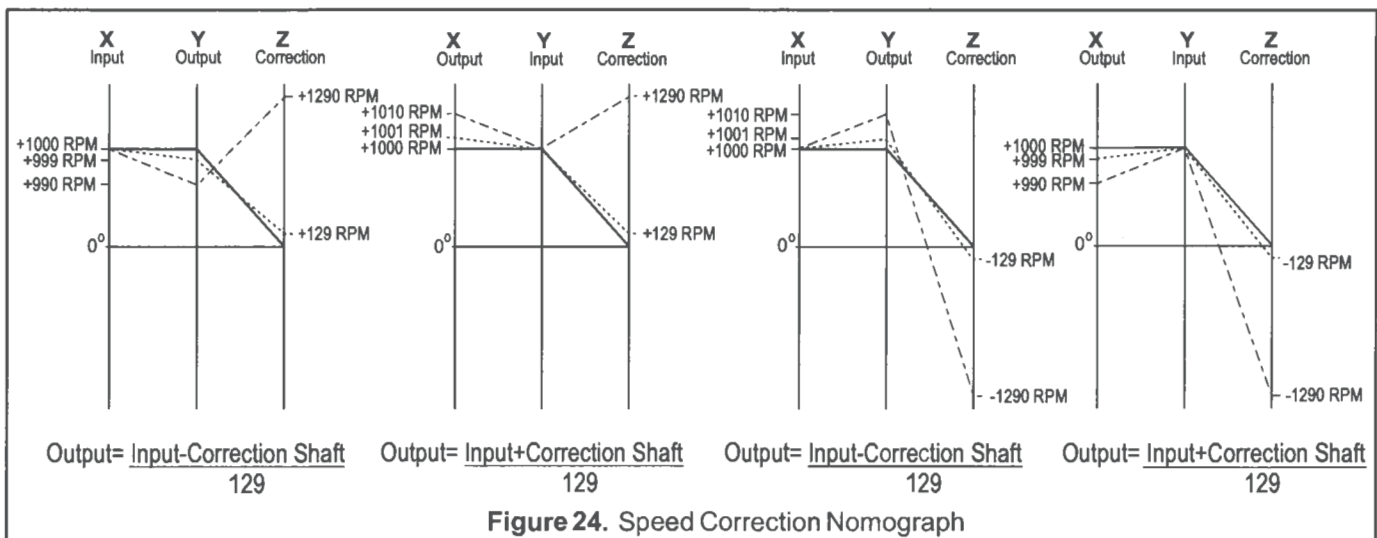



# ASSEMBLY ARRANGEMENTS

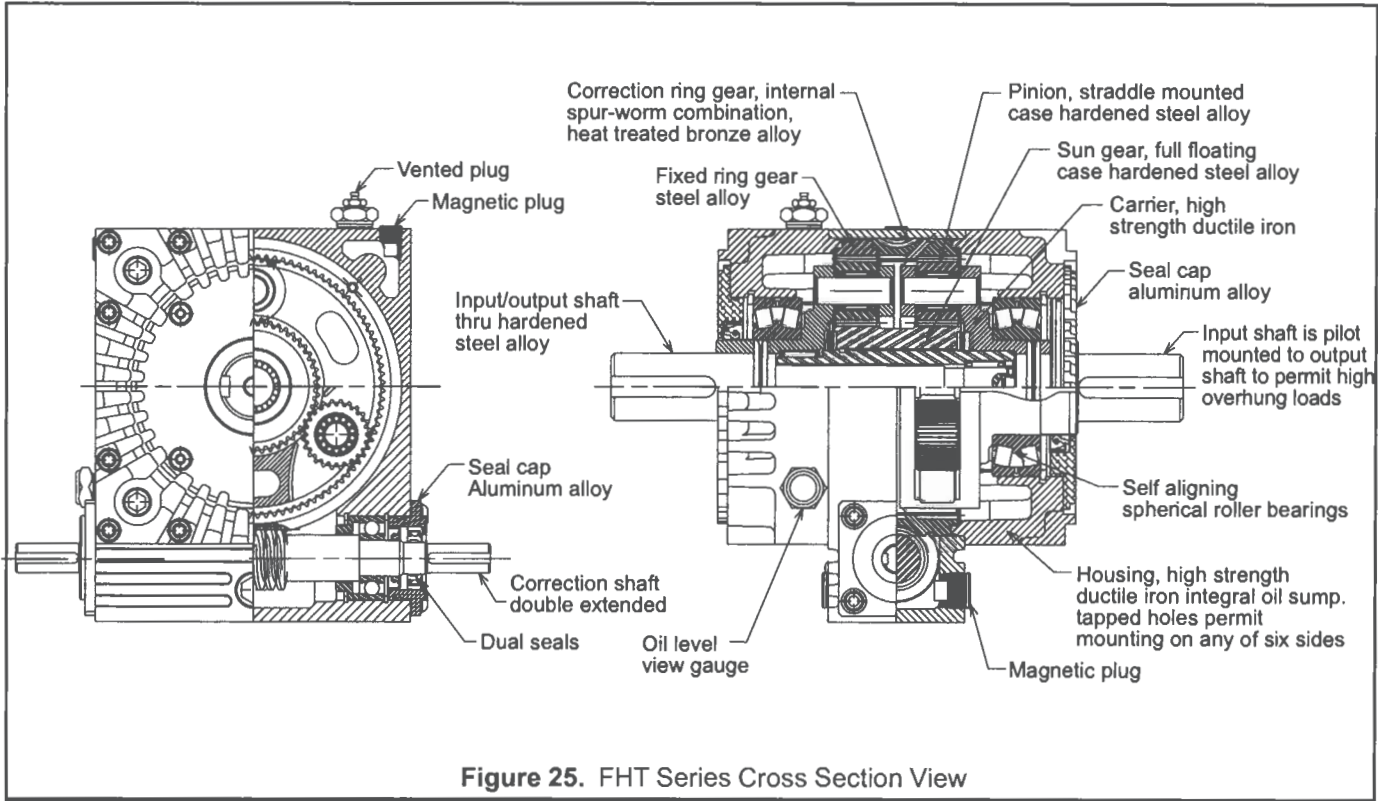

Figure 25. FHT Series Cross Section View

The customer should specify the mounting arrangements as follows:

1. The assembled unit is composed of three separate zones.

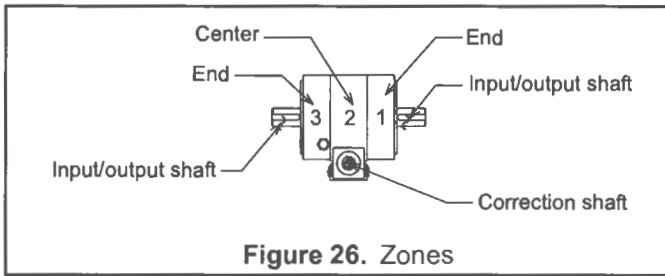

Figure 26. Zones

2. Both ends (1 and 3) have tapped holes for pilot face and/or wall, floor, or ceiling mounting (refer to figure for dimensions and relative locations). Following are the possible arrangements of the ends.

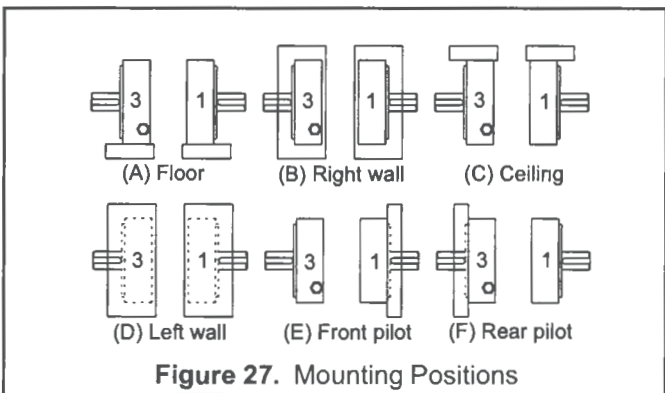

Figure 27. Mounting Positions

3. The center correction shaft can be positioned (1) horizontal floor (2) vertical right (3) horizontal ceiling (4) vertical left. Following are the possible positions:

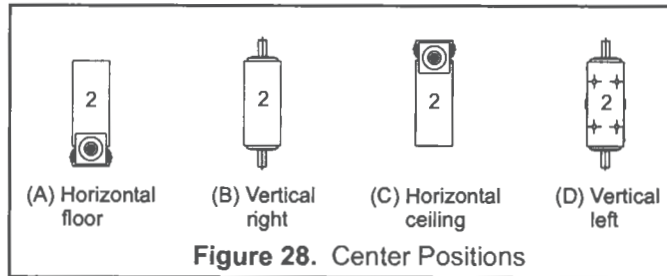

Figure 28. Center Positions

4. Because all three zones of the transmission unit can be positioned independently relative to each other, it is necessary to specify the required position of each successive zone. Each zone is referenced by numbers 1, 2, 3 (See Figure 26). The required assembly is simply represented by the letters corresponding to the desired position of each zone.

5. Example:  
Assembly AAA describes a unit that is floor mounted at end bell (1). The correction shaft (2) is horizontal on the floor and the end bell (3) is also floor mounted.

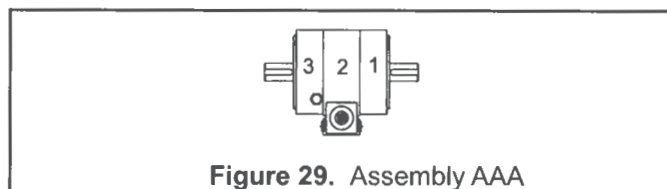

Figure 29. Assembly AAA

6. Following are three additional examples of how to specify the desired assembly:

- a) A unit that is to be pilot mounted on both ends (1 and 3) with the correction shaft horizontal (to wards the ceiling) would be specified by assembly ECF.

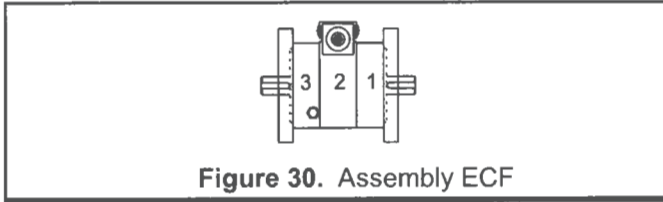

Figure 30. Assembly ECF

- b) A unit that is to be pilot mounted on end (1) with the correction shaft vertical right would be specified by assembly EB (only two letters required because end (3) is not needed for mounting purposes).

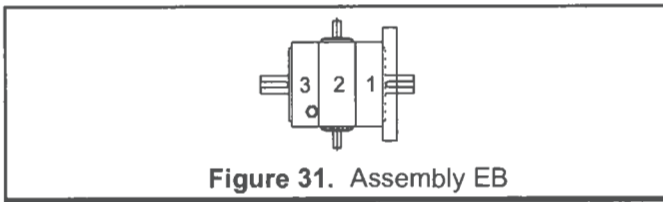

Figure 31. Assembly EB

- c) A unit that is to be ceiling mounted on end bell (1) with the correction shaft vertical towards the right wall and end (3) mounted vertical towards the left wall would be specified by assembly CBD.

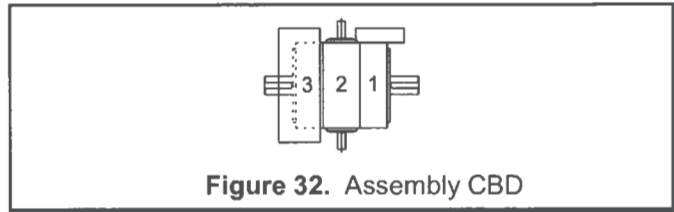

Figure 32. Assembly CBD

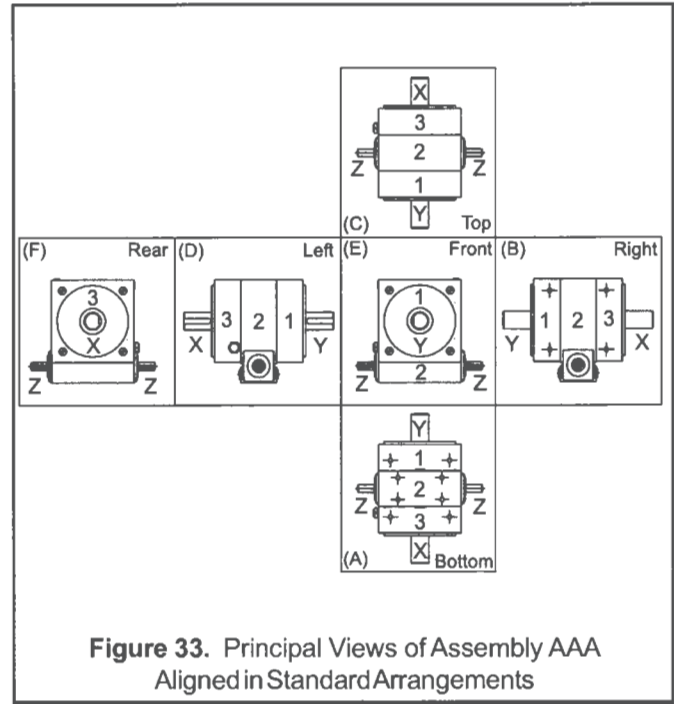

Figure 33. Principal Views of Assembly AAA Aligned in Standard Arrangements

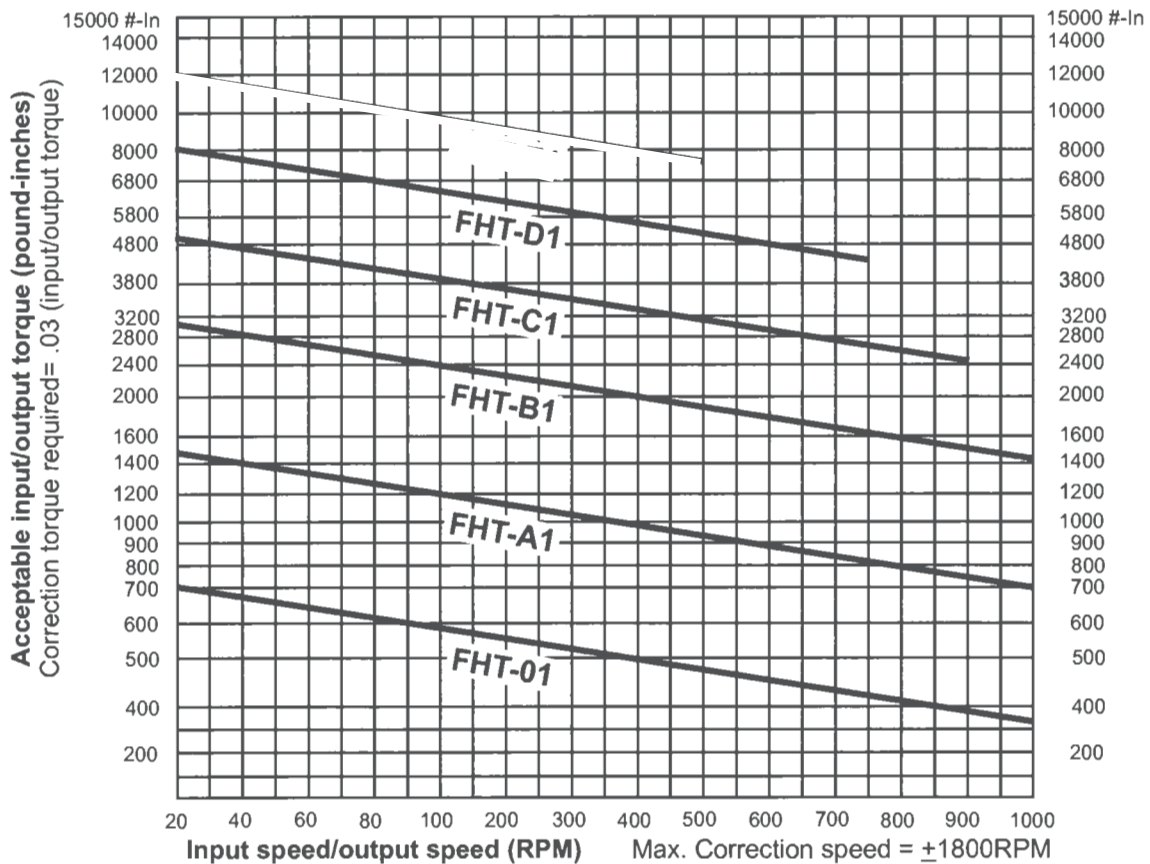

Figure 34. FHT Series Torque Capacity

## ORDERING INFORMATION

When ordering, specify unit series, unit size, shaft diameters in metric (MM) or English (inches) units, and type of assembly. For FRS or FRN, specify shifter position. For FRN, also specify Forward or Reverse.

For example, specify:

FT - C1 metric, assembly B

FRA -D1 metric, assembly AD

FRS -A1 inches, assembly CD, position TR

FRN - B1 metric, assembly AD, position EU,  
reverse

FHT -A1 inches, assembly FCF

### CAUTION:

If the transmission is driving or being driven through a belt, chain, or gear drive, overhung loads will be encountered. Care must be taken not to exceed the overhung capacity of the unit. Use the following formula to calculate overhung load.

Overhung Load =  $2TK/D$

T = Actual Torque (pound-inches)

D = Pitch diameter of sprocket, pulley, or gear

K = 1.0 for chain drive

1.25 for gear drive

1.25 for gear belt drive

### NOTE:

After calculating, refer to tables 10, 11, and 12 on page 18 for maximum overhung load capacity.

In selecting the required size of Cubic Differential, follow these steps:

1. Determine the speed requirement of the driven machine.

**Example:** 750 rpm Input, 750 rpm Output

2. Determine the required torque of the driven machine.

**Example:** 560 LB-IN

3. Refer to Table 11 and select the application factor.

**Example:** 1.25

4. Calculate the design torque by multiplying the required torque by the application factor and temperature factor.

**Example:**  $1.25 \times 560 \text{ LB-IN} \times 1.0 = 700 \text{ LB-IN}$

5. Referring to the torque capacity chart, find the point where the required speed (750) intersects the Design Torque (700 LB-IN).

6. Select the unit size whose torque curve lies nearest and above the point of intersection. SELECT FHT-A1.

- 7.

Select the assembly arrangement required.

## SERVICE INFORMATION

A list of replacement parts and instructions for servicing the CUBIC® Differential Transmission is available in the Installation, Operating and Maintenance Instructions Bulletin 216 IOM.



ISO 2015 Certified



Catalog 216E  
Litho in USA  
Rev. E 11/01