

# CT/CTB-FH SERIES DIMENSIONS

## (3 STAGE, RATIO 75~500)

Precision Spiral Bevel Gearbox

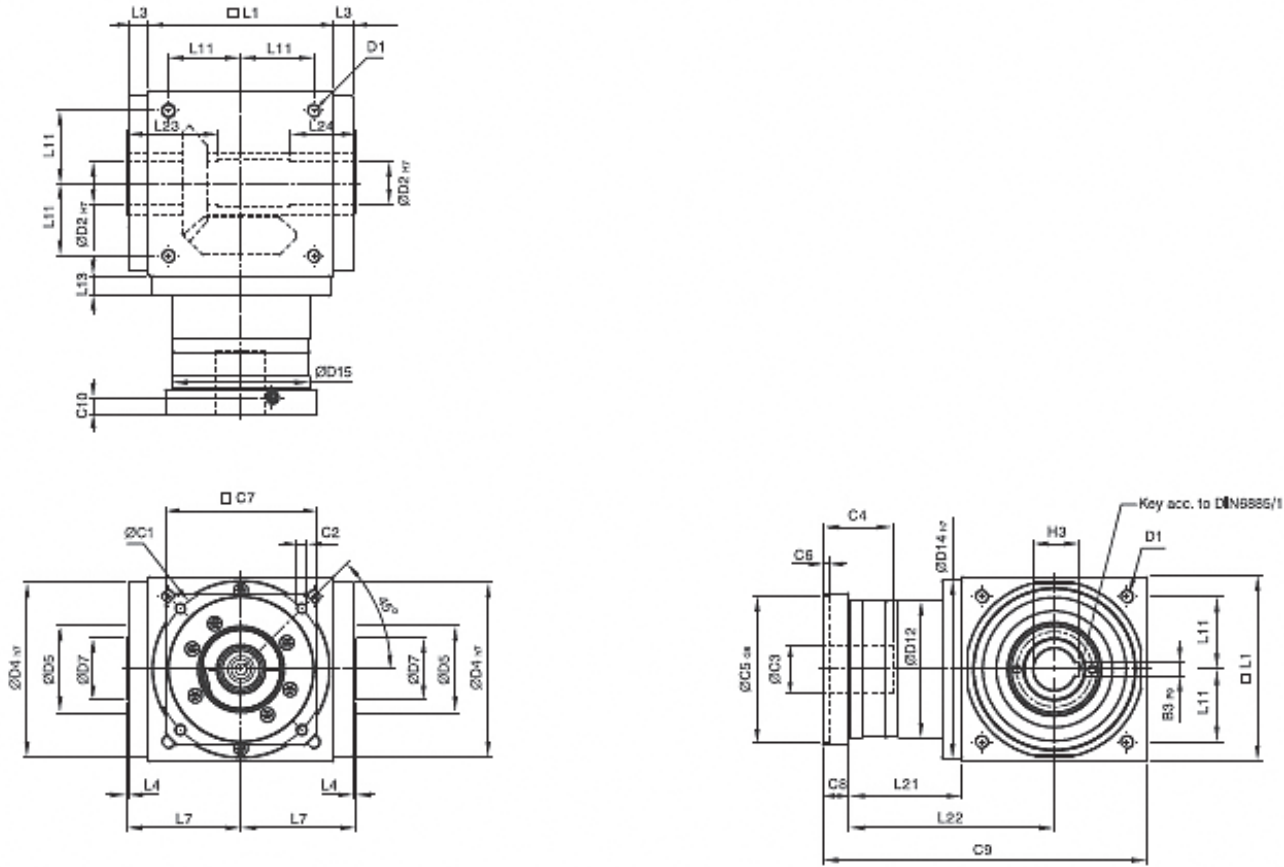

DIMENSION	MODEL NUMBERS					
	CT/CTB110FH	CT/CTB140FH	CT/CTB170FH	CT/CTB210FH	CT/CTB240FH	CT/CTB280FH
D1	M8	M10	M12	M16	M16	M16
D2 (H7)	22	32	40	50	55	60
D4 (h7)	108	135	165	205	235	275
D5	53	68	83	104	124	144
D7	33	47	55	75	85	110
D12	106	104	128	160	180	200
D14 (h7)	108	135	165	205	235	275
D15	107	106	130	158	178	198
L1	110	140	170	210	240	280
L3	15	15	15	20	25	25
L4	2	2	2	2	2	2
L7	72	87	102	127	147	167
L11	44	55	67	85	95	110
L13	15	15	15	20	25	25
L21	136.5	159.5	183.5	226	269	278
L22	191.5	229.5	268.5	331	389	418
L23	53	70	80	95	115	115
L24	35	50	55	65	80	80
C1*(12)	46	46	70	70	100	100
C2*(12)	M4	M4	M5	M5	M6	M6
C3*(12)	≤ 12	≤ 12	≤ 16	≤ 16	≤ 24	≤ 24
C4*(12)	30	30	34	34	40	40
C5*(12)	30	30	50	50	80	80
C6*(12)	3.5	3.5	8	8	4	4
C7*(12)	42	42	60	60	92	92
C8*(12)	21.5	21.5	21.5	21.5	20	20
C9*(12)	268	321	375	457.5	529	578
C10*(12)	14.5	14.5	15.5	15.5	13	13
B3 (P9)	6	10	12	14	16	18
H3	24.8	35.3	43.3	53.8	59.3	64.4

\* C1-C10 are motor specific dimensions, metric standard shown. Contact Candy Controls for your specific motor.