

# CT/CTB-FL & FL1 DIMENSIONS

## (2 STAGE, RATIO 7~50)

Precision Spiral Bevel Gearbox

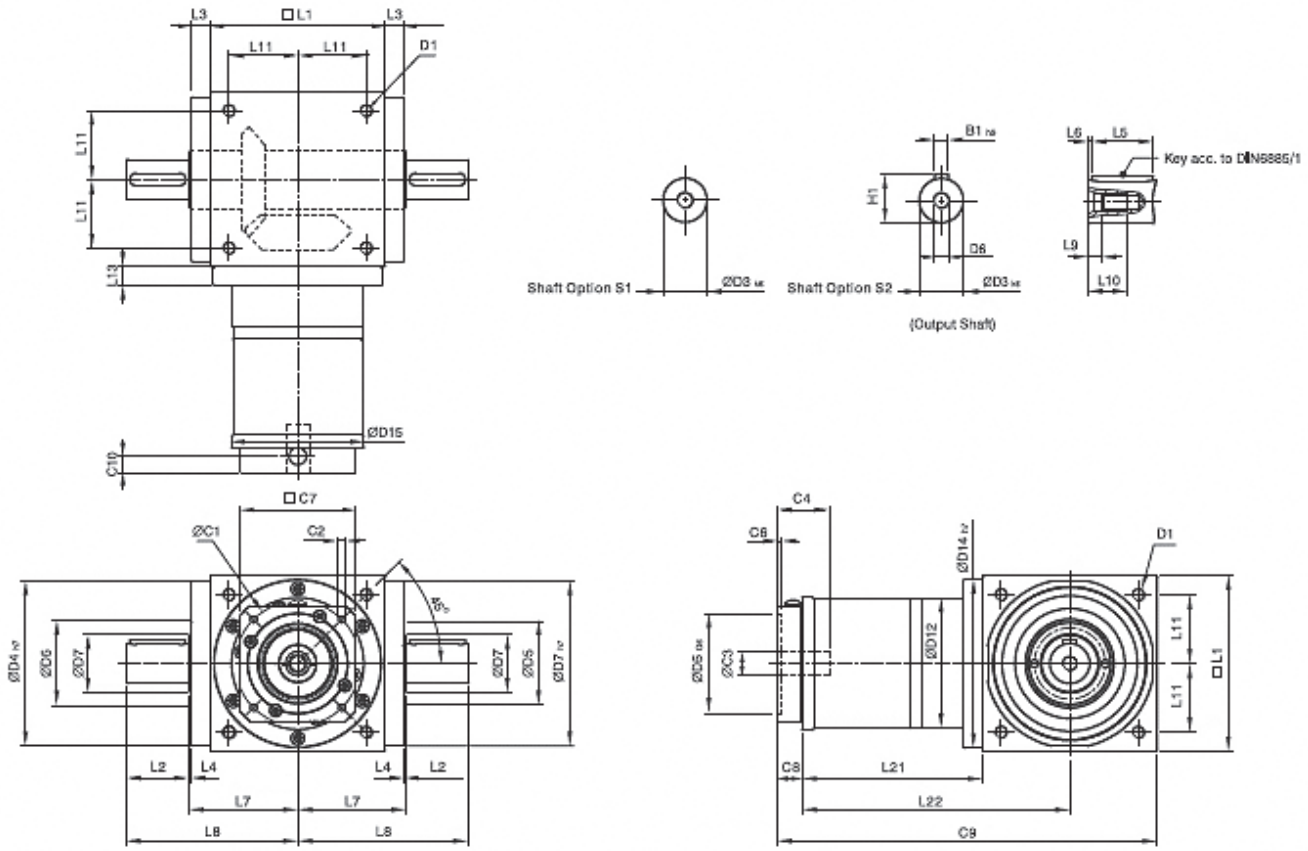

CT/CTB-FL pictured above. CT/CTB-FL1 is without the shaft on the right.

DIMENSION	MODEL NUMBERS								
	CT/CTB065FL/FL1	CT/CTB075FL/FL1	CT/CTB090FL/FL1	CT/CTB110FL/FL1	CT/CTB140FL/FL1	CT/CTB170FL/FL1	CT/CTB210FL/FL1	CT/CTB240FL/FL1	CT/CTB280FL/FL1
D1	M4	M6	M6	M8	M10	M12	M16	M16	M16
D3 (k6)	13	16	18	22	32	40	50	55	60
D4 (h7)	63	73	88	108	135	165	205	235	275
D5	31	35	43	53	68	83	104	124	144
D6	M4	M5	M5	M8	M12	M16	M16	M16	M20
D7	21	22	28	33	47	55	75	85	110
D12	62	72	86	106	104	128	160	180	200
D14 (h7)	63	73	88	108	135	165	205	235	275
D15	62.9	72.9	87	107	106	130	158	178	198
L1	65	75	90	110	140	170	210	240	280
L2	19.5	30	35	40	50	60	75	85	110
L3	13	14.5	15	15	15	15	20	25	25
L4	2	2	2	2	2	2	2	2	2
L5	16	25	28	32	45	50	70	80	100
L6	2	2.5	3.5	4	2.5	5	2.5	2.5	5
L7	47.5	54	62	72	87	102	127	147	167
L8	67	84	97	112	137	162	202	232	277
L9	4.5	4.8	4.8	7.2	10	12	12	12	15
L10	10	12.5	12.5	19	28	36	36	36	42
L11	27	30	36	44	55	67	85	95	110
L13	13	15	15	15	15	15	20	25	25
L21	75	84.5	99	122	144.5	157.5	206.5	239	248
L22	107.5	122	144	177	214.5	242.5	311.5	359	388
C1*(3)	46	46	70	100	100	100	130	165	165
C2*(3)	M4	M4	M5	M6	M6	M6	M8	M10	M10
C3*(3)	≤ 12	≤ 12	≤ 16	≤ 24	≤ 24	≤ 24	≤ 32	≤ 38	≤ 38
C4*(3)	30	30	34	40	40	40	50	60	60
C5*(3)	30	30	50	80	80	80	110	130	130
C6*(3)	3.5	3.5	8	4	4	4	5	6	6
C7*(3)	42	42	60	92	92	92	115	142	142
C8*(3)	21.5	21.5	21.5	20	20	20	24	31	31
C9*(3)	161.5	181	210.5	252	304.5	347.5	440.5	510	559
C10*(3)	14.4	14.5	15.5	13	13	13	16	21	21
B1 (h9)	5	5	6	6	10	12	14	16	18
H1	15	18	20.5	24.5	35	43	53.5	59	64

\* C1-C10 are motor specific dimensions, metric standard shown. Refer to factory for your specific motor mounting system.