

Candy Phasing Hub

Static Phase Adjusting Coupling - 360° Positioner

- Infinitely variable, bi-directional phase adjustment
- Unique design allows for “wrenchless” timing changes
- Eliminates downtime during start-ups and changeovers



OVER 50 YEARS OF INNOVATION

Typical Applications

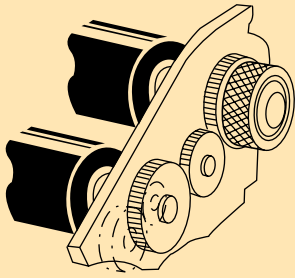

Phasing printing, cutting and/or perforating cylinders

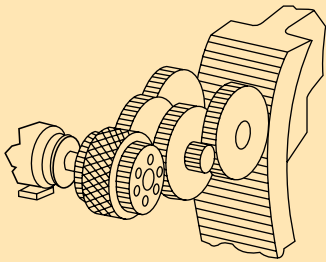

Tuning dual gear trains to eliminate backlash

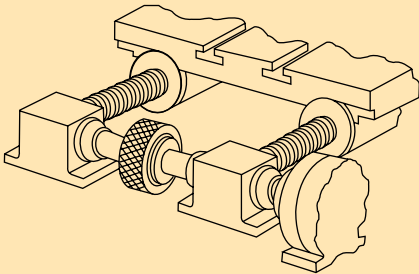

Aligning machine tool parts



Description

The Phasing Hub is a static phase adjusting coupling designed for precise rotary positioning. When in motion, the Phasing Hub operates as a 1:1 rigid shaft coupling. Adjustment of the coupling and connected shafts is accomplished with the drive stopped. By manually rotating the knurled Adjusting Ring, the Phasing Hub becomes a phase changing device providing infinitely variable and stepless phase correction. As the drive engages, the Phasing Hub again operates as a rigid coupling with a new relative position between input and output elements.

Many machines and machine elements require precise angular adjustment between operating components. The need for this adjustment results from rotational misalignment at set-up, material deviation, wear and various other scenarios. The Phasing Hub is a unique, cost effective solution for such timing challenges.

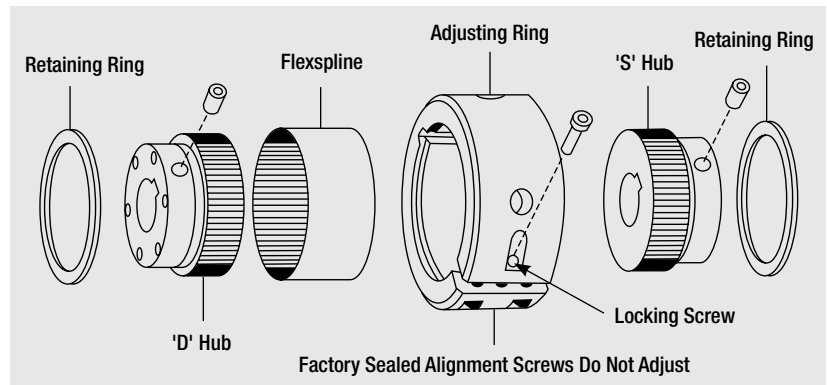

Principle of Operation

The Phasing Hub's operation is based on the Harmonic Drive principle. There are four primary components in each Phasing Hub: The Adjusting Ring, the Flexspline with teeth machined into its inside diameter, a Hub with the same number of teeth as the Flexspline cut into its outer diameter, and a Hub with two less teeth than the Flexspline cut into its outer diameter.

The bore of the Adjusting Ring is not round, but is ellipse-like in shape. The Flexspline, with internal teeth, is inserted into the bore of the Adjusting Ring. In this manner, the Flexspline is deflected slightly to conform to the ellipse-like shape of the Adjusting Ring. The two Hubs with external teeth then mate with the internal teeth of the Flexspline.

Under normal running conditions, there is no relative rotation of the elements, and the Phasing Hub functions as a rigid shaft coupling. However, when the Adjusting Ring is manually rotated, the assembly creates a 100:1 ratio allowing for static phase adjustments as the two Hubs with different numbers of teeth are walked around a common axis by the Flexspline. One complete rotation of the Adjusting Ring creates 3.6 degrees of phase change at the output. For micro adjustments, Candy provides a graduated scale on the Adjusting Ring, which lines up with a mark on the inner Hub. Each graduation of this scale represents 0.1 degrees of phase change on the output element.

Technical Data

CONSTRUCTION

The Hubs are manufactured from low carbon steel and have a phosphate coating. The Adjusting Ring is also carbon steel with a black oxide coating. Applications involving hostile environments, including wash down conditions, may not be suitable for the standard materials.

LOCKING SCREW

Phasing Hub is essentially self-locking in continuously rotating applications involving relatively low speeds and torques. In such applications, it may not be necessary to seat the locking screw located on the Adjusting Ring. However, intermittent applications involving high speeds and torques will require the use of the locking screw to maintain a desired phase setting. Once the locking screw is tightened, there is no backlash in the Phasing Hub's tooth mesh.

DIRECTION OF PHASE ADJUSTMENT

As discussed in the previous sections, the Phasing Hub consists of two Hubs with different numbers of teeth. One Hub is stamped and referred to as the "S" Hub, while the other is stamped and referred to as the "D" Hub. The graduated scale (available for the PH 1000, 2500 and 5000) is mounted to the Adjusting Ring around the "S" Hub.

When the "S" Hub is driven, rotation of the Adjusting Ring will cause the output to change its rotational position in the same direction as the rotation applied to the Adjusting Ring. If the Adjusting Ring is rotated in the clockwise direction, the output element will correct in the clockwise direction. If the "D" Hub is driven, the output shaft will correct in a direction opposite to the rotation applied to the Adjusting Ring. If the Adjusting Ring is rotated in the clockwise direction, the output element will correct in the counterclockwise direction.

LUBRICATION

The Phasing Hub is factory lubricated and will not require further maintenance under normal operating conditions. If the Phasing Hub is in a hostile environment, Candy recommends a periodic lubrication schedule. To lubricate the Phasing Hub, loosen the locking screw and remove the retaining rings from each side of the Adjusting Ring. Remove both Hubs from the Phasing Hub and generously grease the teeth with a multi-purpose lubrication. Reassemble in the reverse order, making sure that both Hubs and bores are concentric with one another. Caution, it is possible to assemble one of the Hubs off center by one tooth.

Note: The Phasing Hub is not to be used as a torque multiplier nor is it designed to accommodate shaft misalignment.

Mounting/Installation

The Phasing Hub may be installed in a machine either as an in-line shaft coupling or as a concentric shaft coupling providing phase adjustment for parallel shafts.

IN-LINE SHAFT COUPLING

In order to ensure proper shaft alignment, either the driven or driving shaft should pass completely through one Hub and pilot into the other by an amount determined by the "L" dimension shown below.

The Phasing Hub is designed to transmit pure torque only. Radial loads and misalignment must be isolated from the Phasing Hub. This may be achieved by using shaft bearing supports or a flexible coupling adapter.

CONCENTRIC SHAFT COUPLING

The shaft should pass completely through the attached sprocket or gear and the Phasing Hub at a uniform diameter with a tight running fit. Refer to the illustration shown below.

In-line Shaft

Size	L DIM
PH 500	.86
PH 1000	1.09
PH 2500	1.34
PH 5000	1.43
PH 10000	1.88
PH 20000	2.25

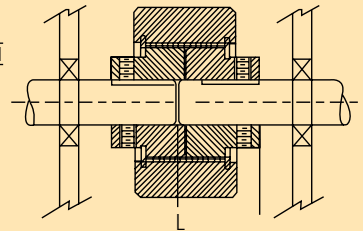

In-line Shaft

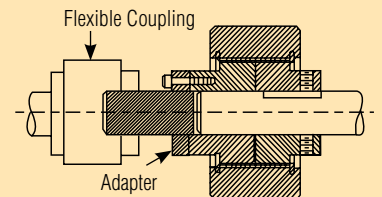

Concentric Shaft

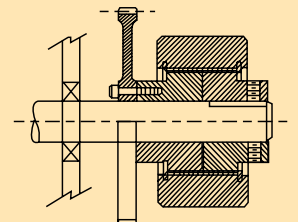

Ordering

The Phasing Hub is available in six sizes and must be ordered based on the required running torque and shaft size. The tabulated torque ratings are for continuous applications with shaft rotation in the same direction. For intermittent and bi-directional applications, the maximum torque and inertia conditions must be considered.

Each Phasing Hub may be ordered with a minimum plain bore (smallest available bore size) or with any of the standard options shown in the ordering chart. Please note that the standard options apply to both Hubs. Custom bores and mounting configurations are available upon factory request.

PHASING HUB SPECIFICATIONS

Model	Continuous Torque	Bore Range	Shipping Weight
PH 500	500 lb.-in.	.250" - .500"	1.2 lb.
PH 1000	1,000 lb.-in.	.500" - .750"	1.5 lb.
PH 2500	2,500 lb.-in.	.750" - 1.000"	3 lb.
PH 5000	5,000 lb.-in.	1.000" - 1.250"	5 lb.
PH 10000	10,000 lb.-in.	1.250" - 1.750"	11 lb.
PH 20000	20,000 lb.-in.	1.750" - 2.500"	24 lb.

STANDARD BORE OPTIONS

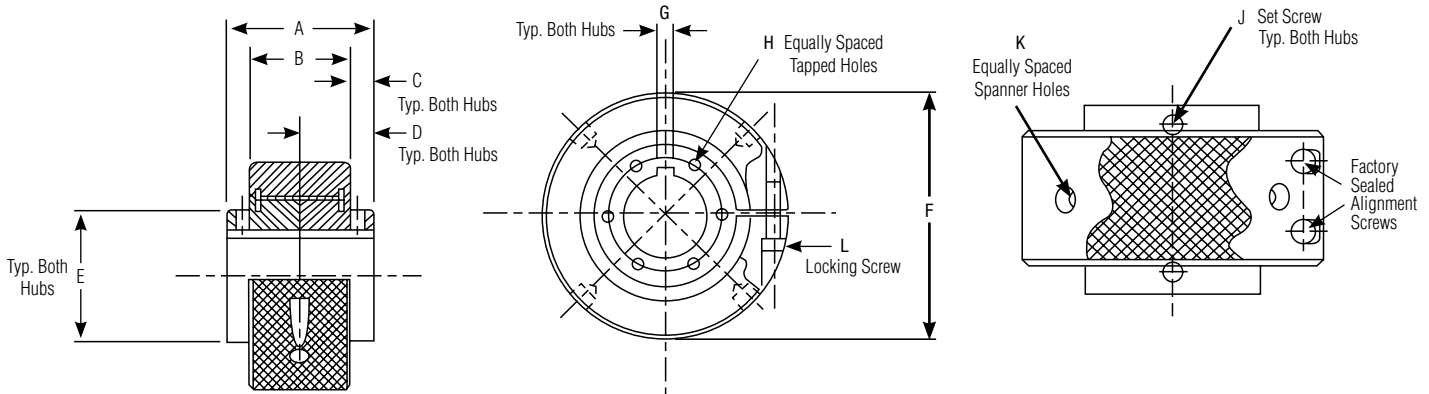
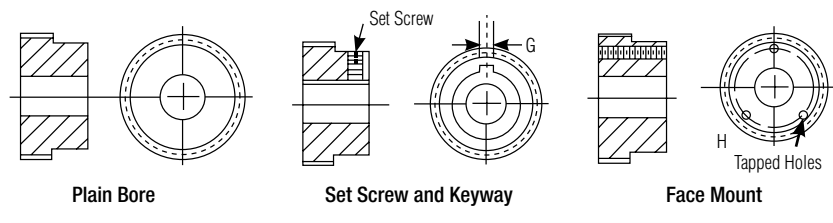

PHASING HUB DIMENSIONS

Model	A	B	C	D	E	F	G	H	J	K	L
PH 500	1.43	.91	.26	.713	.995	2.00	.062/.125	(3) 6-32, .750 B.C.	8-32	—	M3
PH 1000	1.69	1.06	.31	.840	1.38	2.38	.1875	(3) 8-32, 1.125 B.C.	1/4-20	—	M4
PH 2500	2.19	1.38	.40	1.086	1.75	3.00	.250	(6) 10-32, 1.500 B.C.	1/4-20	(4) .34	M4
PH 5000	2.37	1.63	.37	1.179	2.17	3.75	.250	(6) 1/4-20, 1.750 B.C.	1/4-20	(4) .34	M5
PH 10000	3.29	2.06	.61	1.625	2.94	4.75	.375	(6) 5/16-18, 2.500 B.C.	3/8-16	(4) .39	M6
PH 20000	4.05	2.38	.84	2.00	3.75	6.50	.625	(6) 3/8-16, 3.125 B.C.	1/2-13	(4) .53	M8

Note: All dimensions, with the exception of the locking screw are in inches. All dimensions and specifications are subject to change.
 ©2012 Candy Mfg. Co., Inc. Printed in USA



Candy Mfg Co., Inc.

5633 West Howard Street
 Niles, IL 60714 USA

tel: 847-588-2639
 fax: 847-588-0055

info@candycontrols.com
 www.candycontrols.com